

Controller features

ASTRO 6AH

Operation Manual

Modified Date:10-09-2024



Vietnamese CNC Controllers

INTRODUCTIONS:

Thank you for your interest and choose our motion controller. QS Technology Co.,LTD provide controllers with a modern design also with operation interface. The ASTRO 6AH controller was designed for multi applications. This controller can support a wide range of applications thanks to the flexible integration of the main core (Motion control), PLC and Macro.

This user guide provides you with an overview of the range of functions of QS Technology milling controllers and gives you a good experience for your daily work.

QS Technology Co., Ltd. We are proud to be a pioneer in developing, applying, and marketing CNC controller products "Made by Vietnam." After many years of development, products under the QS Technology brand have increasingly gained the trust and interest of customers both domestically and internationally. Additionally, with strengths and experience accumulated over many years in machine manufacturing, automation systems, and electronic circuit boards, we are confident in our mastery of the technology and our ability to meet our customers' needs.

OUR WEBSITE



CONTENT

INTRODUCTIONS:	0
CHAPTER 1:	4
CONTROLLER OVERVIEW	4
1.1 APPERANCE	5
1.2 DIMENSION	6
1.3 SOFTWARE STRUCTURE	8
1.4 FUNCTION KEYS	9
CHAPTER 2:	14
WIRING - CONNECTION	14
2.1 POWER SUPPLY	15
2.2 SENSOR CONNECTION PORT	16
2.2.1 HIGH INPUT VOLTAGE	16
2.2.2 LOW INPUT VOLTAGE	17
2.2.3 ASTRO 6AH CONTROLLER INPUT CONNECTION TABLE	18
2.3 TOOL LENGTH SENSOR	18
2.3.1 3 WIRES TYPE	18
2.3.2 4-WIRES-NPN TYPE	19
2.3.2 4-WIRES-PNP TYPE	19
2.3.3 6-WIRE-NPN TYPE	20
2.3.4 6-WIRE-PNP TYPE	20
2.4 AXIS WIRING DIAGRAM	21
2.4.1 WIRING DIAGRAM X-Y AXIS (PUL/DIR)	21
2.4.2 WIRING DIAGRAM Z-A AXIS (PUL/DIR)	22
2.4.3 WIRING DIAGRAM B-C AXIS (PUL/DIR)	23
2.5 CONNECT ANALOG SIGNAL TO INVERTER	24
2.6 I/O LINK BOARD CONNECTION	25
2.6.1 I/O LINK BOARD - INPUT PORT (LOW INPUT)	26
2.6.2 I/O LINK BOARD - INPUT PORT (HIGH INPUT)	27
2.6.3 I/O LINK BOARD - OUTPUT PORT	28
2.7 MPG HANDWHEEL WIRING DIAGRAM	30

2.7.1 4 AXIS TYPE – DIFFERENTIAL OUTPUT SIGNAL	30
2.7.2 6 AXIS TYPE – DIFFERENTIAL OUTPUT SIGNAL.....	31
2.7.3 4 AXIS TYPE – NPN OUTPUT SIGNAL	32
2.7.4 6 AXIS TYPE – NPN OUTPUT SIGNAL.....	33
2.7.5 4 AXIS TYPE – PNP OUTPUT TYPE.....	34
2.7.6 6 AXIS TYPE – PNP OUTPUT TYPE.....	35
2.8 HOME SWITCH WIRING DIAGRAM	36
2.8.1 PNP WIRING.....	36
2.8.2 NPN WIRING.....	36
2.9 REFERENCE CONNECTION PORT.....	37
2.9.1 AXIS CONTROL	37
2.9.2 INPUT SIGNAL.....	37
2.9.3 OUTPUT SIGNAL.....	38
2.9.4 OTHER DEVICES	38
CHAPTER 3.	38
OPERATION INTERFACE	39
3.1 MAIN PAGE	40
3.2 COORDINATE PAGE	41
3.2.1 SWITCH SCREEN.....	42
3.2.2 HALF.....	43
3.2.3 ZERO-ZERO ALL	44
3.3 PROGRAM PAGE	46
3.3.1 COPY DATA FROM USB TO CONTROLLER.....	47
3.3.2 EXECUTE PROGRAM.....	48
3.3.3 GO TO ANY COMMAND LINE.....	50
3.3.4 SEARCH FOR AN OBJECT IN PROGRAM AND REPLACE.....	52
3.3.5 DELETE A COMMAND LINE.....	55
3.3.6 COPY AND PASTE	57
3.4 OFFSET PAGE.....	59
3.4.1 MANUAL DATA INPUT.....	60
3.4.2 ASSIGN MACHINE, AUXILIARY COORDINATES TO SPECIFIED COORDINATE SYSTEM.....	61
3.4.3 CALCULATE THE CENTER POINT OF 4 POINTS AND 3 POINTS WORKPIECE.....	63

3.5 MONITOR PAGE.....	65
3.5.1 TOOLPATH SIMULATION.....	66
3.5.2 MDI MODE.....	68
3.5.3 AUTO OPTION MODE.....	69
3.5.3.1 START PROGRAM FROM ANY COMMAND LINE.....	70
3.5.3.2 CONTINUE THE WORKING PROCESS FROM THE LAST STOPPED COMMAND.....	72
3.5.4 WORKING HISTORY.....	74
3.6 MAINTENANCE PAGE	75
3.7 DIAGNOSTIC PAGE	76
3.8 PARAMETER PAGE.....	77
3.8.1 PARAMETER SETTING STEPS.....	78
3.9 PLC PAGE.....	81
3.9.1 FIND AN OBJECT IN LADDER PROGRAM.....	82
3.9.2 IMPORT PLC DATA.....	83
3.10 SYSTEM SETTING.....	87
3.10.1 FIRMWARE UPDATE	89
3.10.2 DATE & TIME SETTING.....	92
3.11 TOOL LENGTH MEASUREMENT SENSOR	94
CHAPTER 4.....	97
PARAMETER INSTRUCTIONS	97
4.1 AXIS PARAMETER	98
4.2 SPINDLE PARAMETER.....	100
4.3 GENERAL PARAMETER.....	101
4.4 USER PARAMETER.....	101
4.5 MACRO PARAMETER.....	101

CHAPTER 1.

CONTROLLER OVERVIEW



1.1 APPERANCE



Figure 1-1. ASTRO 6AH controller



Figure 1-2. ASTRO 6AH controller outside box

1.2 DIMENSION



Figure 1-3. Front view of ASTRO 6AH controller

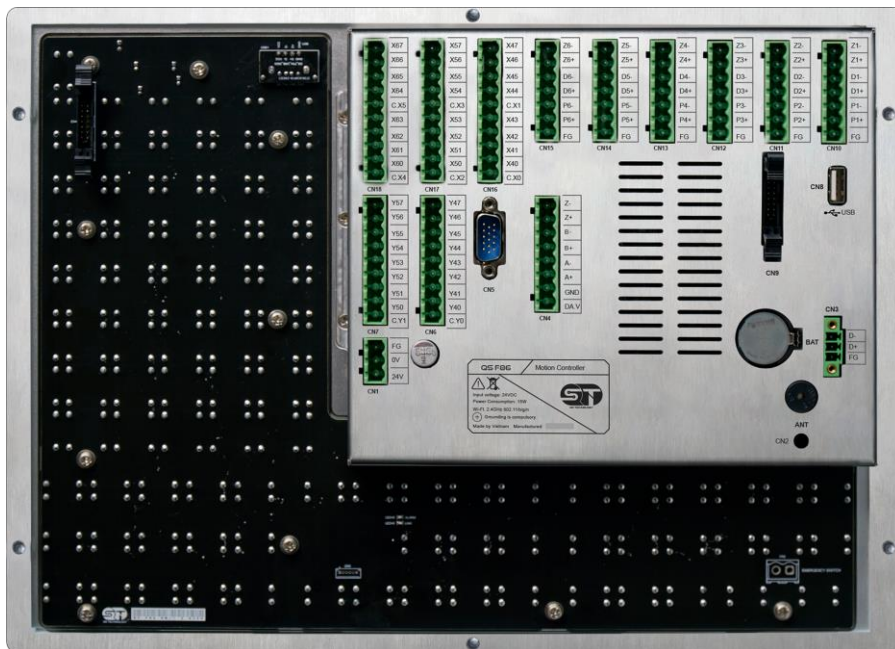

Figure 1-4. Back view of ASTRO 6AH controller



Figure 1-5. Side view of ASTRO 6AH controller

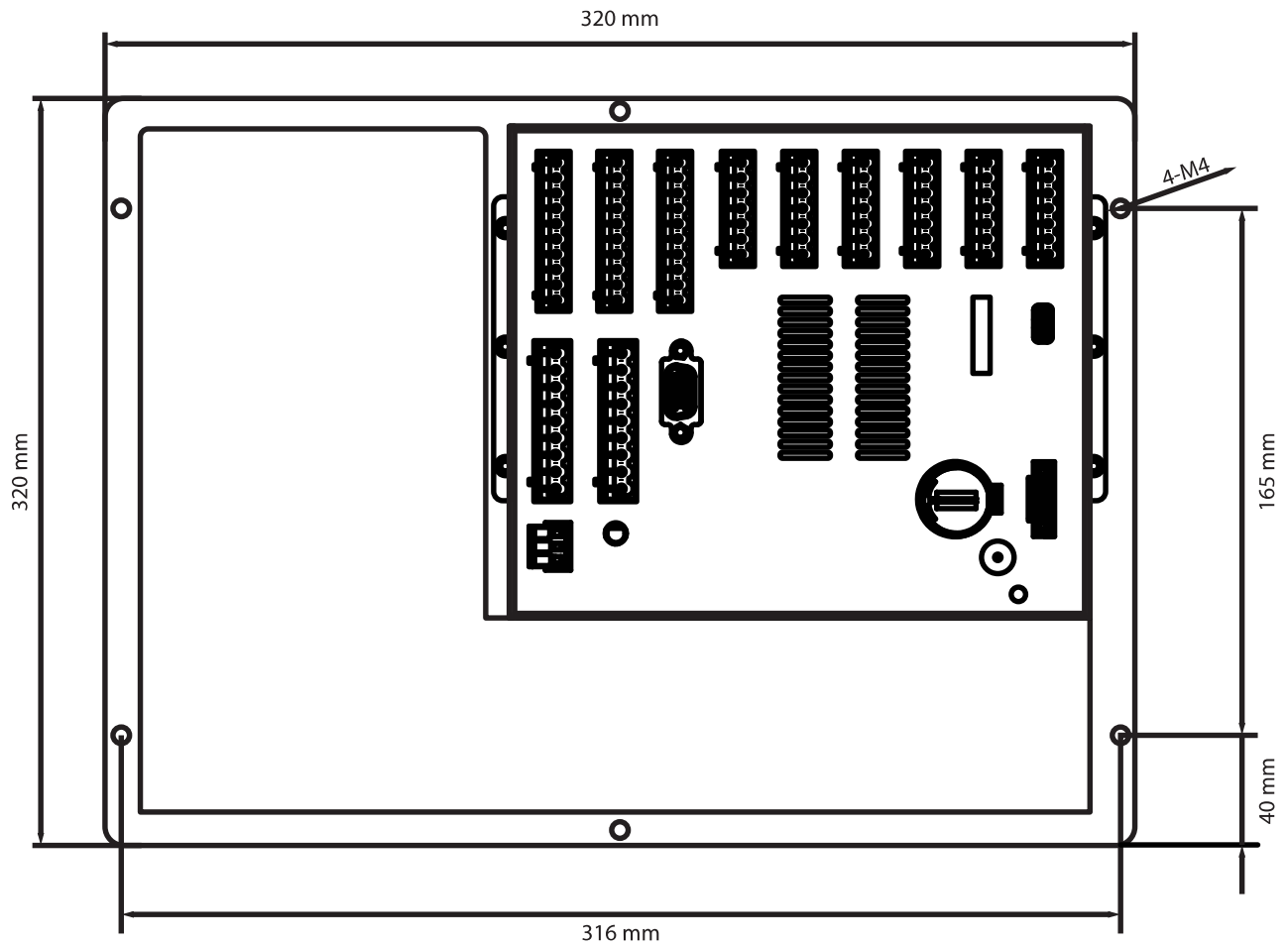

Figure 1-6. Details dimension of ASTRO 6AH controller



1.3 SOFTWARE STRUCTURE

Model: ASTRO 6AH Controller

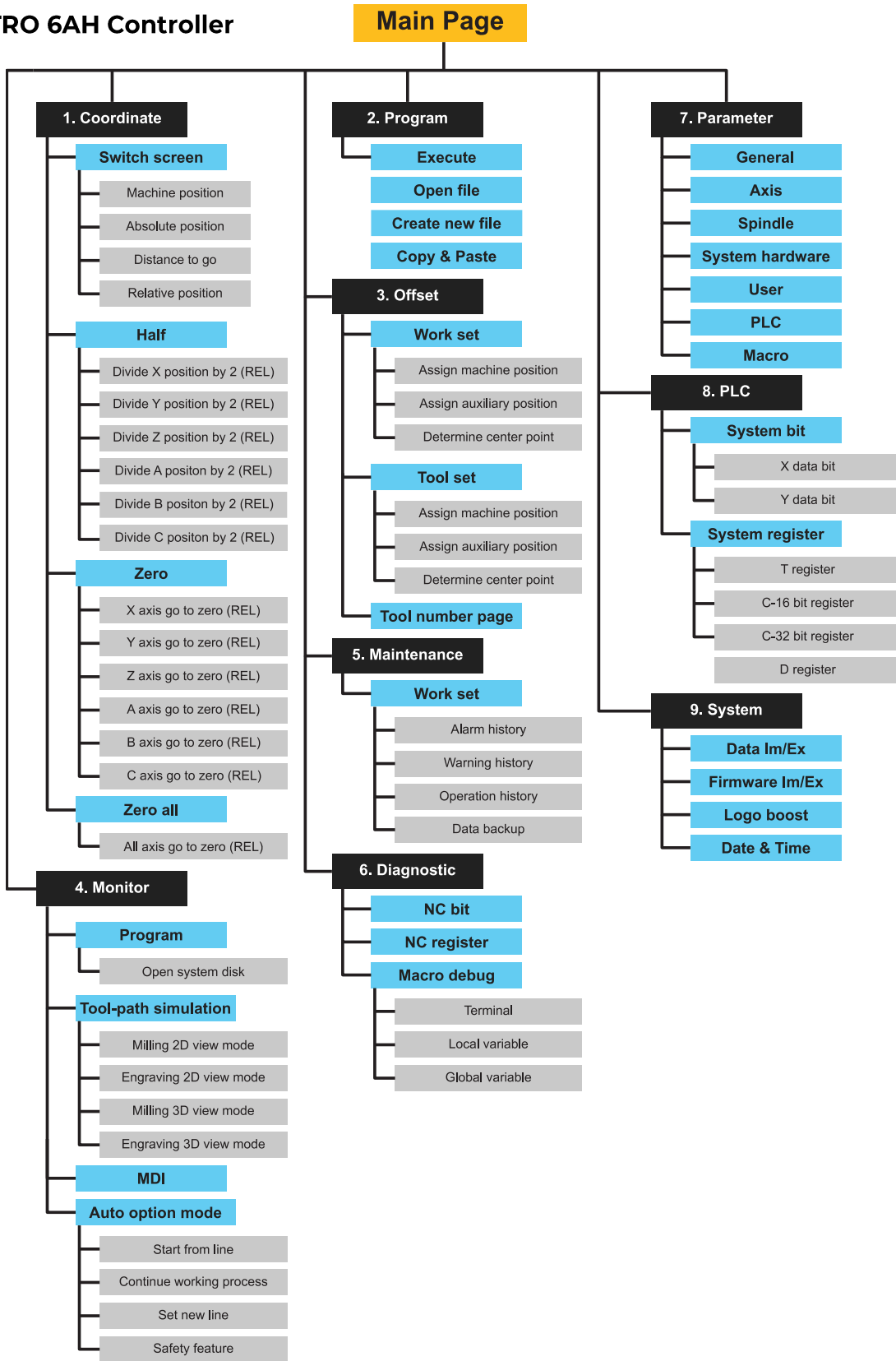













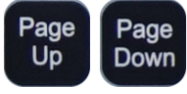







Figure 1-7. ASTRO 6AH controller software structure













1.4 FUNCTION KEYS

The operators need to refer to this table to get the information of function keys before starting the working process.

MODEL	ASTRO 6AH
	Access to COORDINATE page
	Access to PROGRAM page
	Access to OFFSET page
	Access to MONITOR page
	Access to MESSAGE page
	Access to PARAMETER page
	System reset
	Delete an object
	Remove the blank space

	Combine with button to use the secondary character
	Create a blank space
	Confirm
	Scroll page up and down
	Moves to the beginning of the program, combine with SHIFT button to move to the end of the program.
	Switch to AUTO mode
	Switch to MDI mode
	Switch to MPG mode
	Switch to JOG mode
	Switch to INC JOG mode
	Returns to HOME position

	<p>Activate Coolant system</p>
	<p>Activate Air pressure</p>
	<p>BLOCK SKIP function</p>
	<p>OPTIONAL STOP function</p>
	<p>Switch to MPG Feed mode</p>
	<p>Running program without workpiece</p>
	<p>Lock machine</p>
	<p>Activate light</p>
	<p>Release the axis from home switch</p>
	<p>Tool magazine run in clock-wise direction</p>
	<p>Tool magazine run in counter clock-wise direction</p>

	<p>Spindle run in clock-wise direction</p>
	<p>Spindle run in counter clock-wise direction</p>
	<p>Spindle stop</p>
	<p>Adjust spindle speed percent</p>
	<p>Axis direction selection</p>
	<p>Adjust rapid speed (G00)</p>
	<p>Adjust jog speed (G01)</p>
	<p>Chip conveyor run in counter clock-wise direction</p>
	<p>Chip conveyor run in clock-wise direction</p>

	<p>Extension feature button 1 (Modify by user)</p>
	<p>Cycle start button</p>
	<p>Feed hold button</p>
	<p>Movement & Selection button</p>
	<p>USB slot</p>

CHAPTER 2.

WIRING - CONNECTION



2.1 POWER SUPPLY



Figure 2-1. Power supply widely use

Note:

- Using switching power supply is better than voltage transformer
- Voltage input forced to connect FG pin to against the noise signal for controller

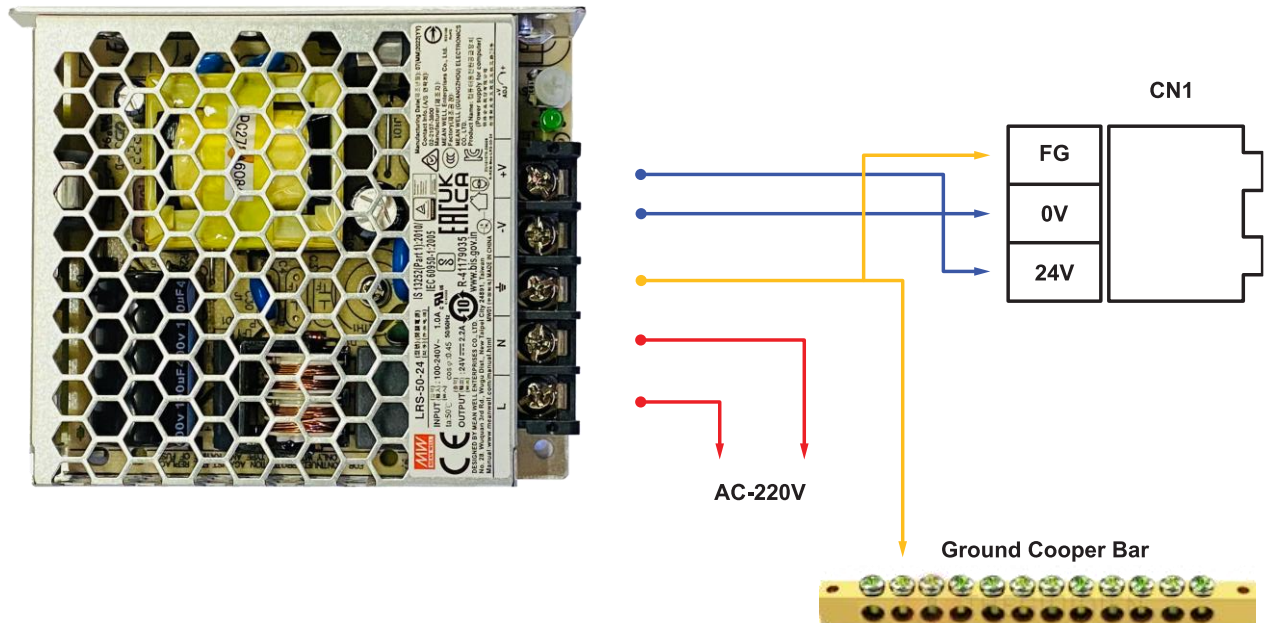

Figure 2-2 Power connection diagram

2.2 SENSOR CONNECTION PORT

There are 2 type of sensor that is widely used is high input (PNP) and low input (NPN).

Notice:

- High input (PNP): When we connect CX pin to 0V and using high input sensor type (PNP). This signal will lead to the input signal of controller
- Low input (NPN): When we connect CX pin to 24V and using low input sensor type (NPN). This signal will lead to the input signal of controller

2.2.1 HIGH INPUT VOLTAGE

User can choose CN16, CN17, CN18 to connect the high input voltage to controller.

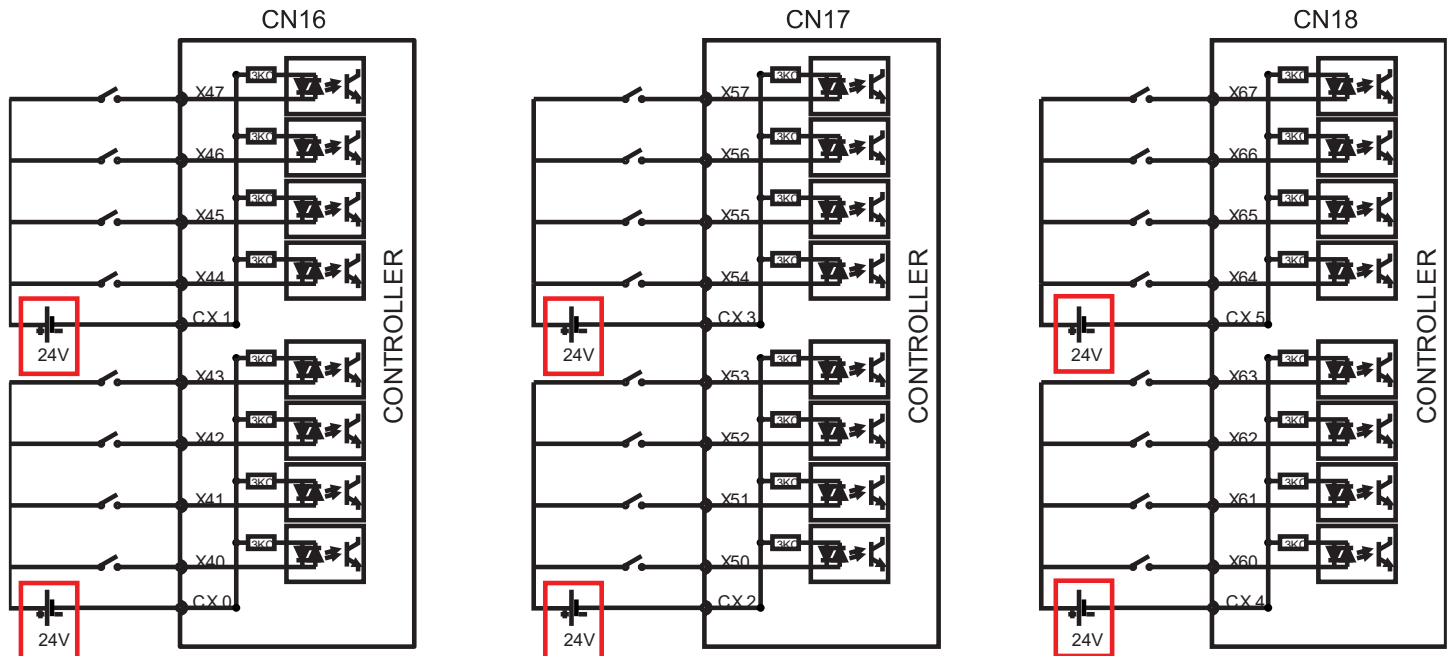

Figure 2-3. High input voltage of CN16, CN17, CN18 port



2.2.2 LOW INPUT VOLTAGE

User can choose CN16, CN17, CN18 to connect the low input voltage to controller

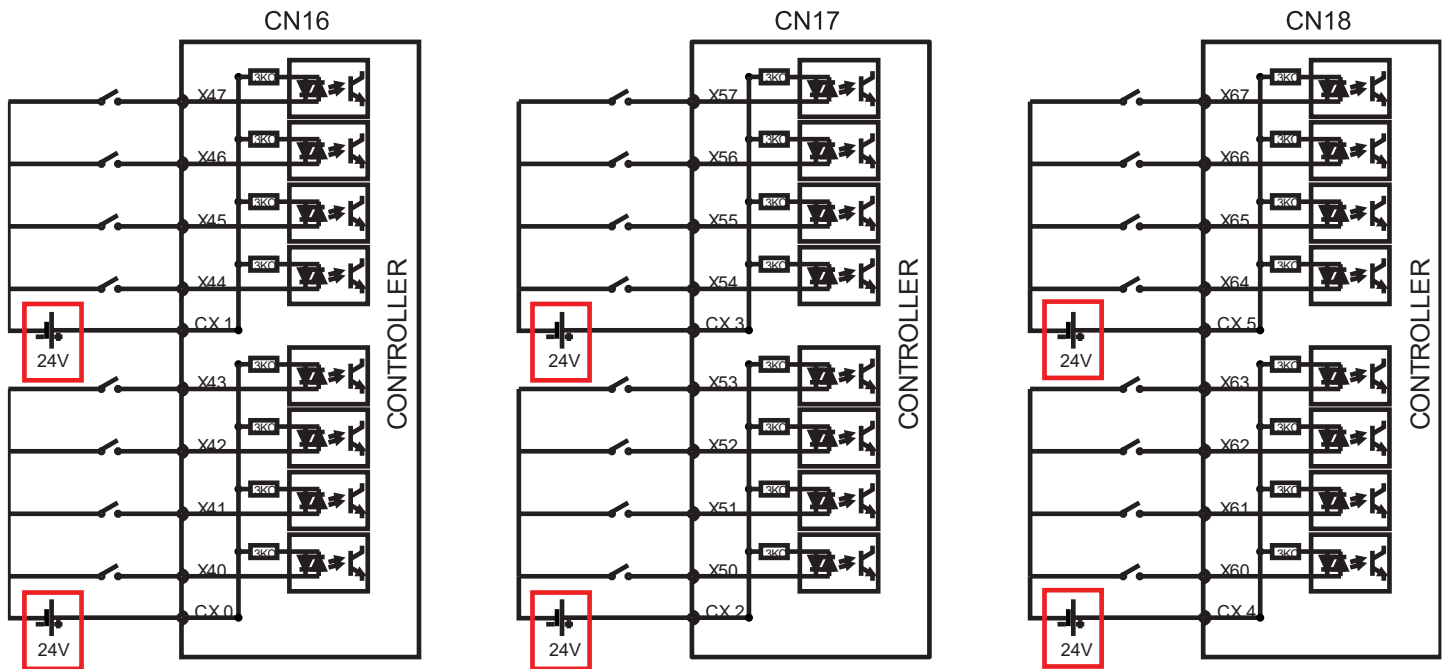

Figure 2-4. Low input voltage of CN16, CN17, CN18 port

Note:

- CX.0, CX.1, CX.2, CX.3, CX.4, CX.5 is a COM separate input signal pins
- Recommend the operators to wire the input signal at the same type
- **DO NOT wire 2 difference type of voltage input signal at the same time to the controller**



2.2.3 ASTRO 6AH CONTROLLER INPUT CONNECTION TABLE

Refer the reference connection table of ASTRO 6AH controller at **(2.9)** below to avoid connecting wrong signal cause damage to device.

2.3 TOOL LENGTH SENSOR

Tool length sensor is a device to measure the length, wear of cutting tools and these values will be calculated to determine the tool wear compensation. And the controller will able to adjust suitable working value achieve the desired dimensions and tolerances of machined parts.

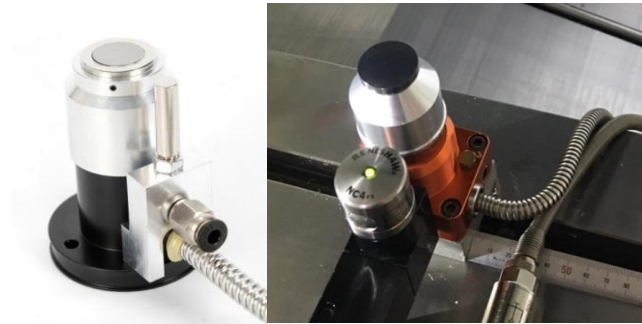

Figure 2-6. Tool length sensor

2.3.1 3 WIRES TYPE

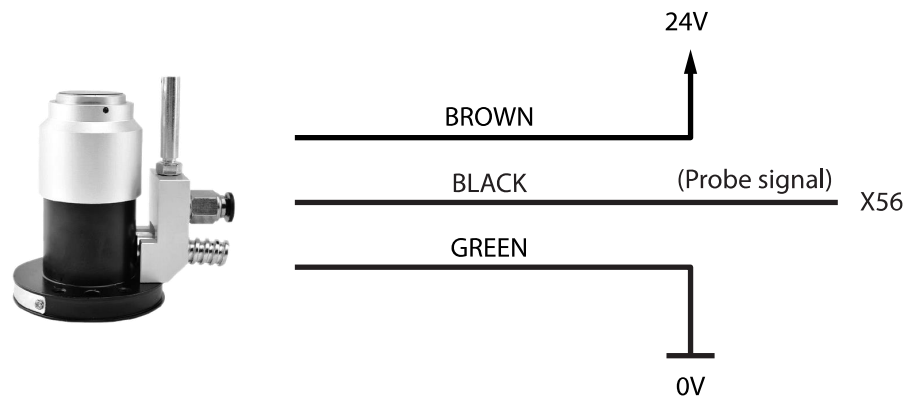

Figure 2-7. Tool length sensor wiring diagram (3 wires type)



2.3.2 4-WIRES-NPN TYPE

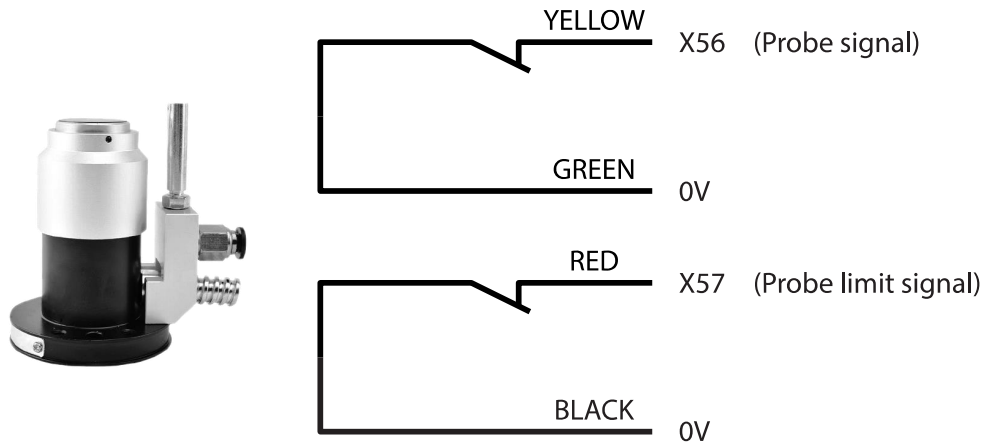

Figure 2-8. Tool length sensor wiring diagram (4 wires-NPN)

2.3.2 4-WIRES-PNP TYPE

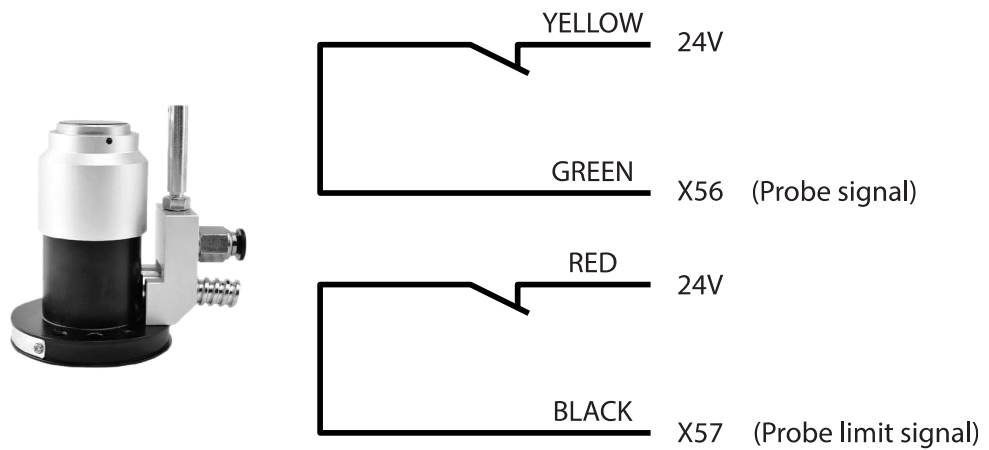

Figure 2-9. Tool length sensor wiring diagram (4 wires-PNP)

2.3.3 6-WIRE-NPN TYPE

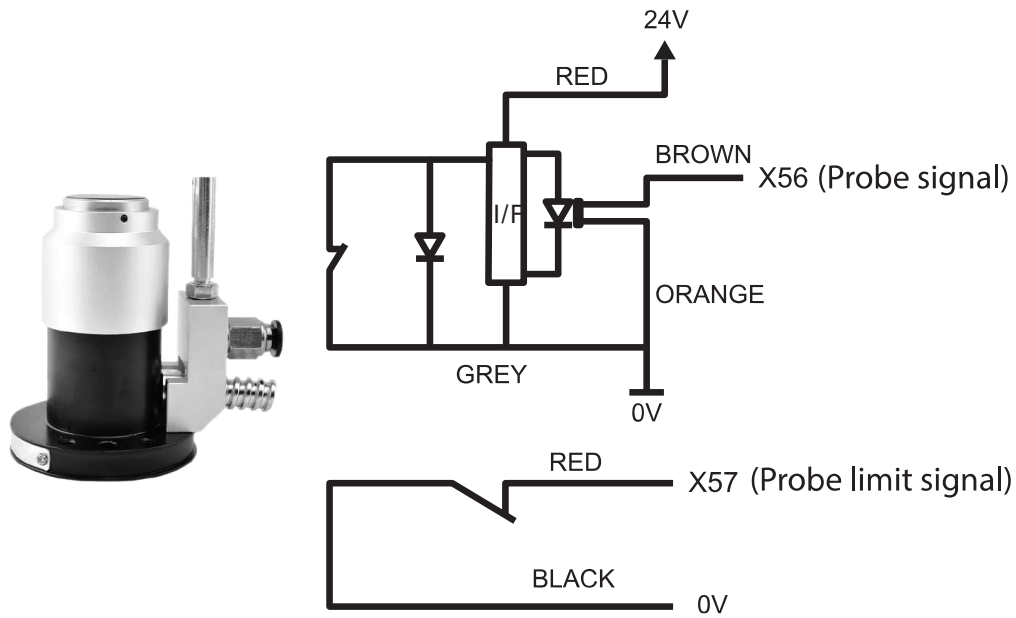

Figure 2-10. Tool length sensor wiring diagram (6 wires-NPN)

2.3.4 6-WIRE-PNP TYPE

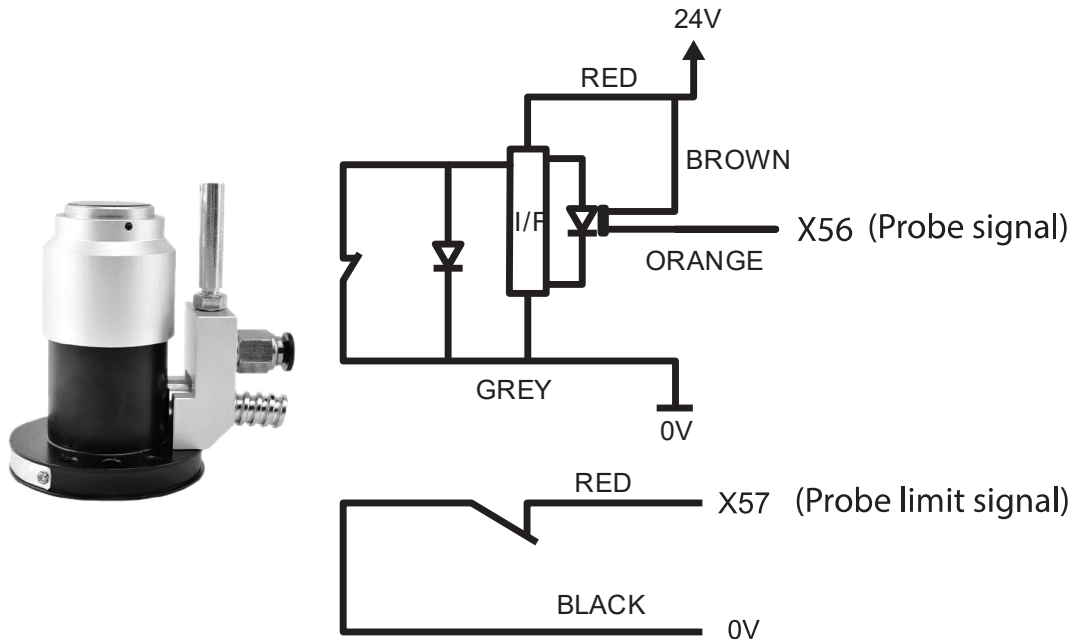

Figure 2-11. Tool length sensor wiring diagram (6 wires-PNP)

2.4 AXIS WIRING DIAGRAM

2.4.1 WIRING DIAGRAM X-Y AXIS (PUL/DIR)

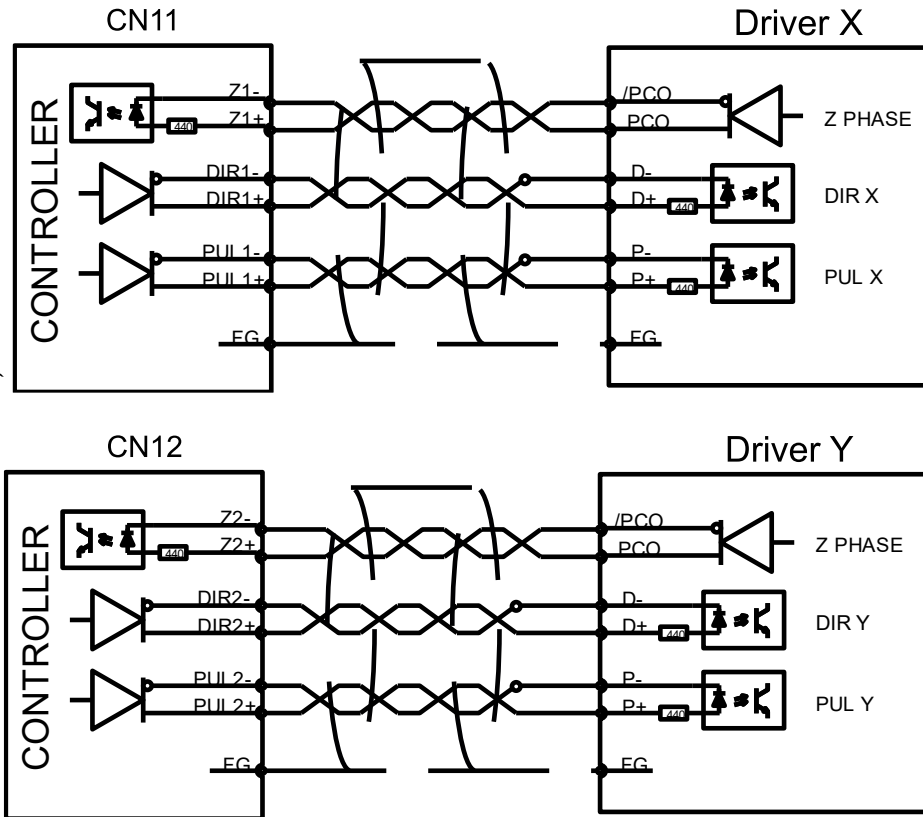

Figure 2-12. X,Y axis pulse/direction wiring diagram

Note:

MODEL		ASTRO 6AH	
		Pulse feedback index Z wiring	

2.4.2 WIRING DIAGRAM Z-A AXIS (PUL/DIR)

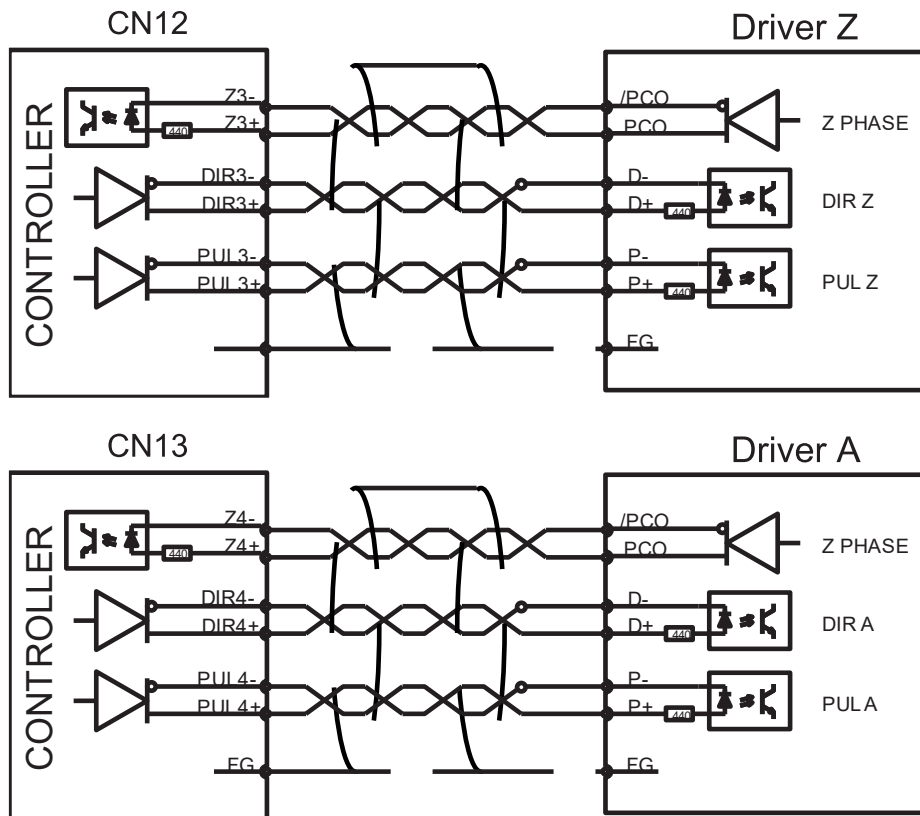

Figure 2-13. Z,A axis pulse/direction wiring diagram

Note:

MODEL	ASTRO 6AH
<p>Z PHASE</p>	Pulse feedback index Z wiring

2.4.3 WIRING DIAGRAM B-C AXIS (PUL/DIR)

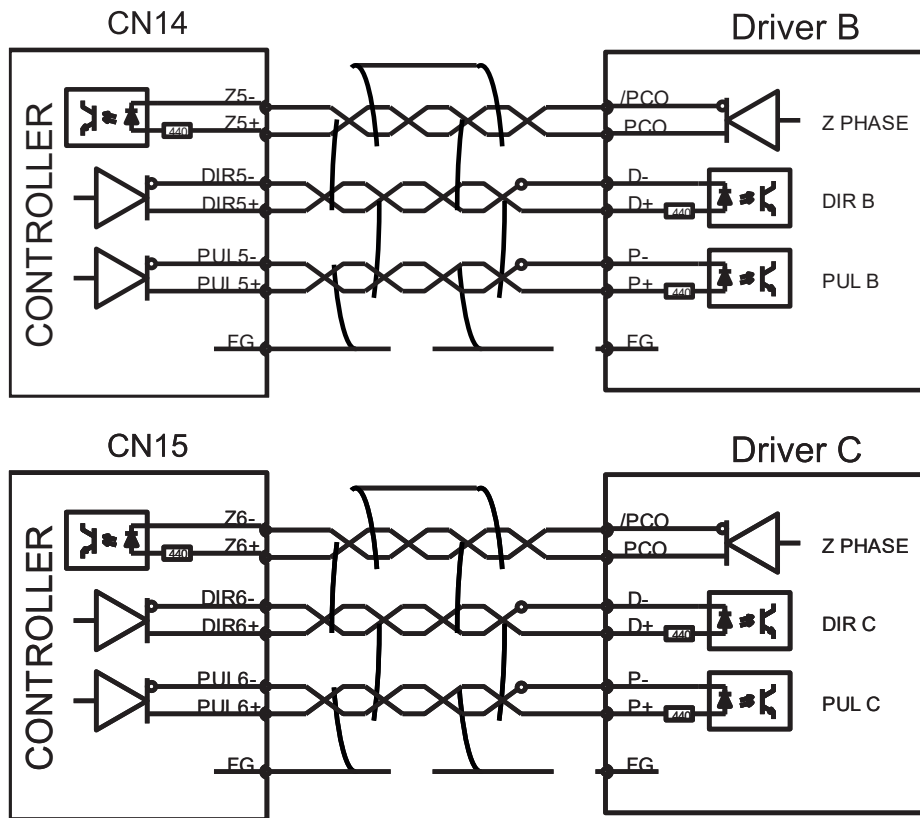

Figure 2-14. B,C axis pulse/direction wiring diagram

Note:

MODEL	ASTRO 6AH
	Pulse feedback index Z wiring

Control cable must have a shield wire and be soldered to the connector to against the noise signal (Refer image below).

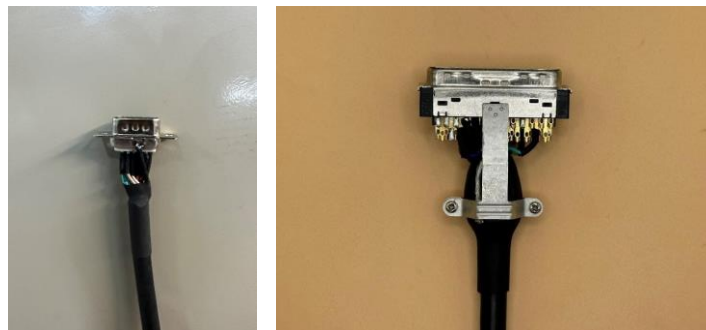

Figure 2-15. Control cable shield wire be soldered to the connector

2.5 CONNECT ANALOG SIGNAL TO INVERTER

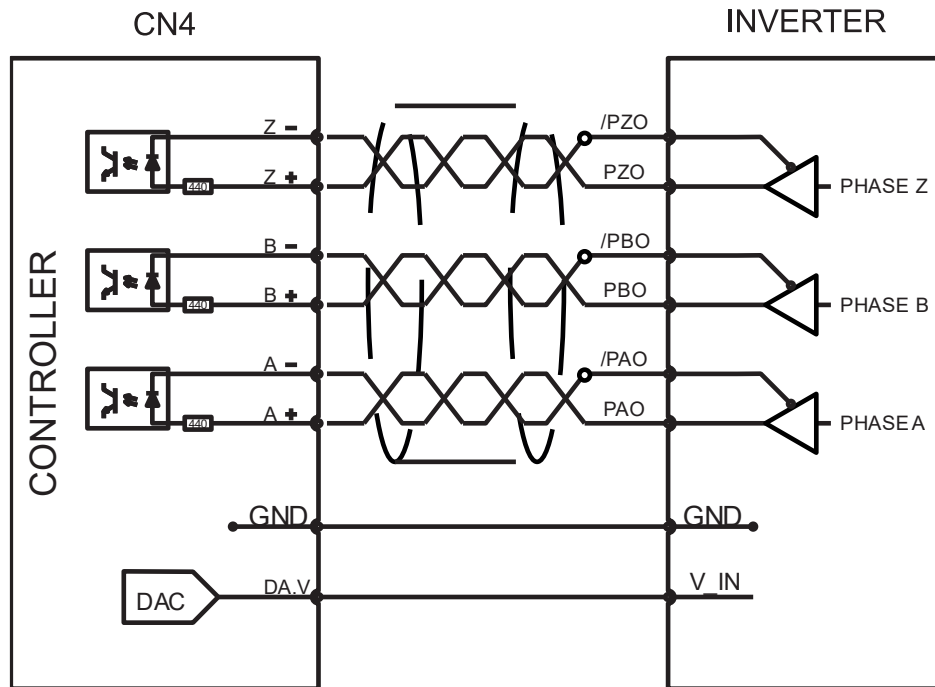

Figure 2-16. Inverter to controller wiring diagram

Note:

MODEL	ASTRO 6AH
<p>The diagram shows a GND terminal on the left connected to a GND terminal on the right. Below this, a DAC output terminal (DA.V) is connected to a V_IN terminal on the right.</p>	<p>Analog output signal to inverter (0-10V)</p>

2.6 I/O LINK BOARD CONNECTION

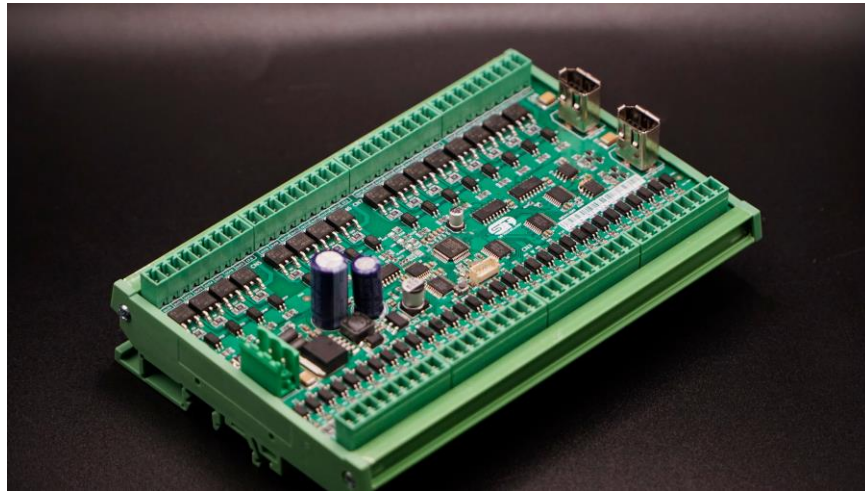

Figure 2-17. I/O link 32_v1.1_0722 board

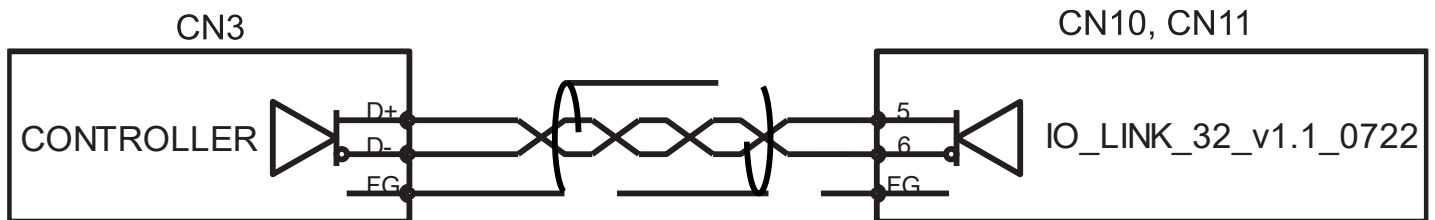

Figure 2-18. I/O link board wiring diagram

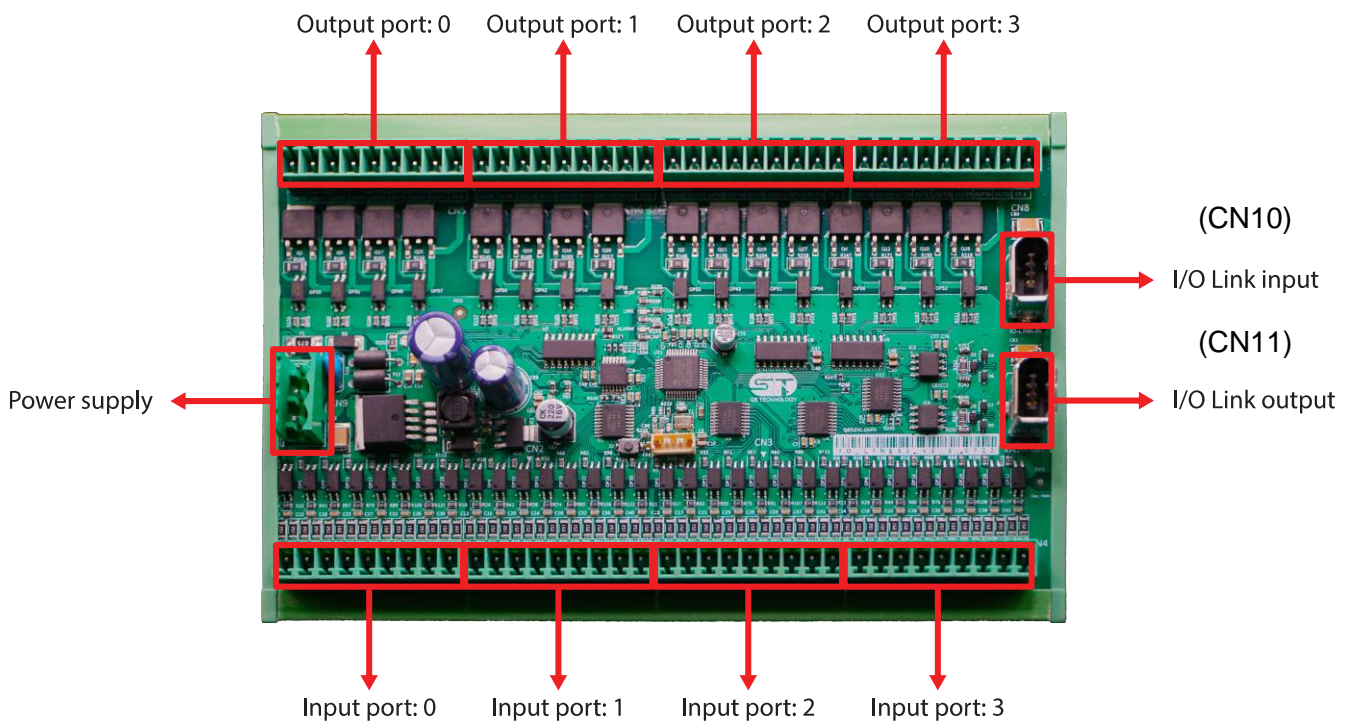
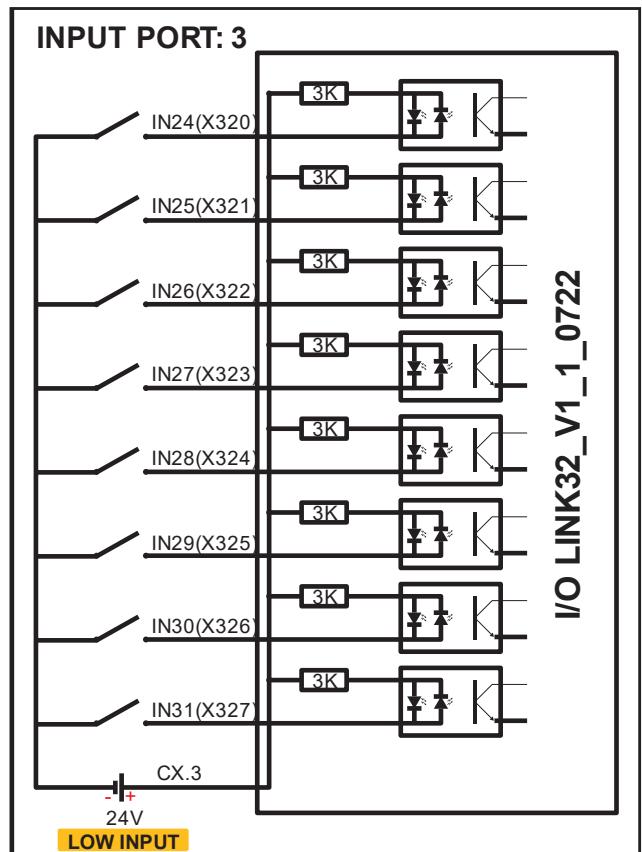
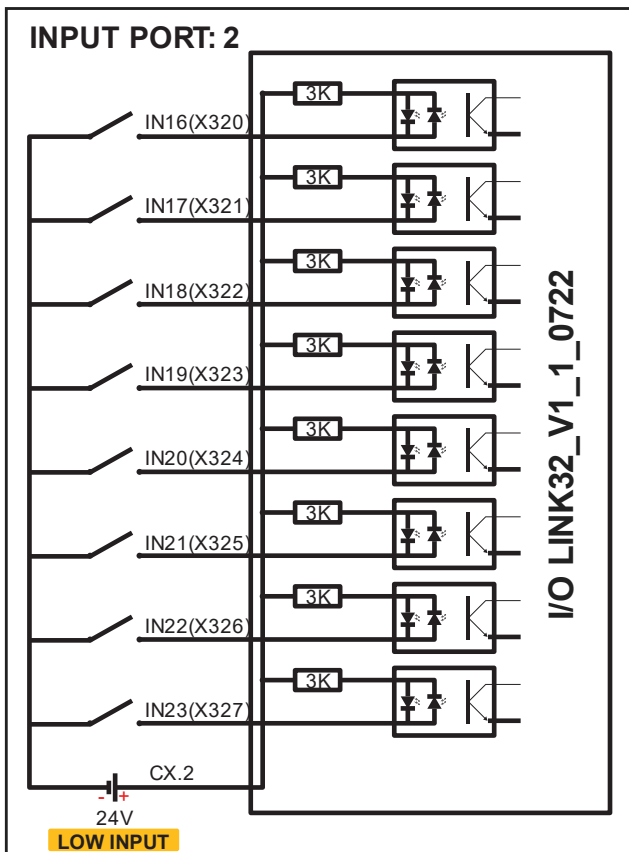
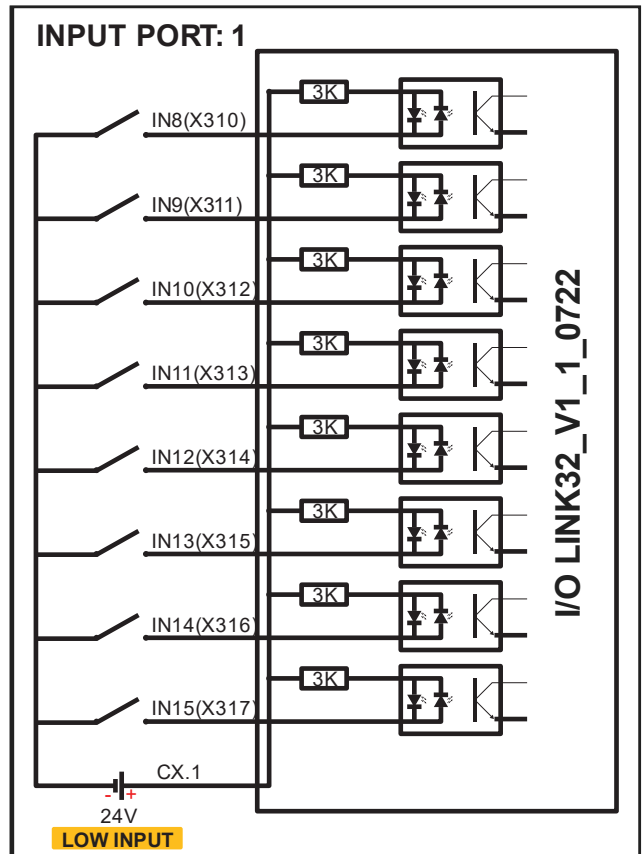
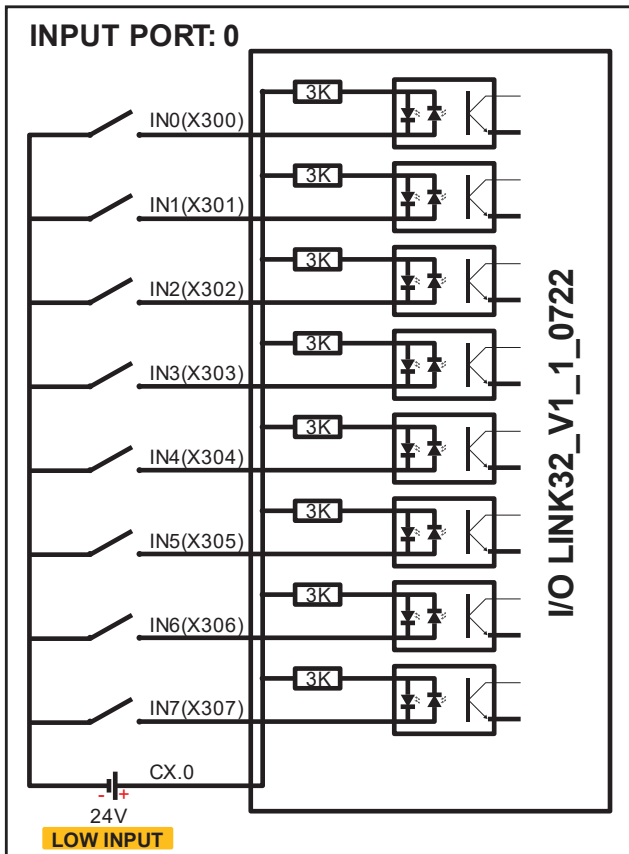
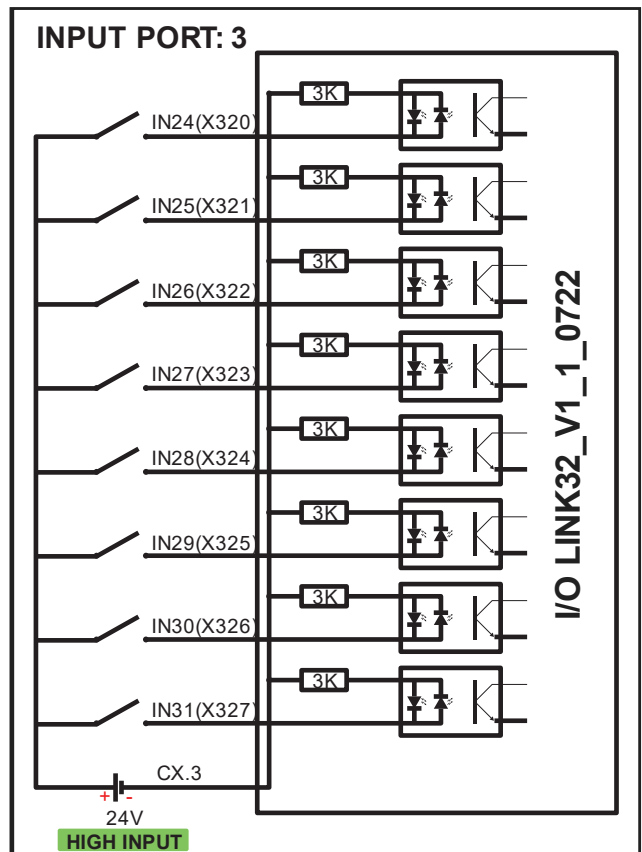
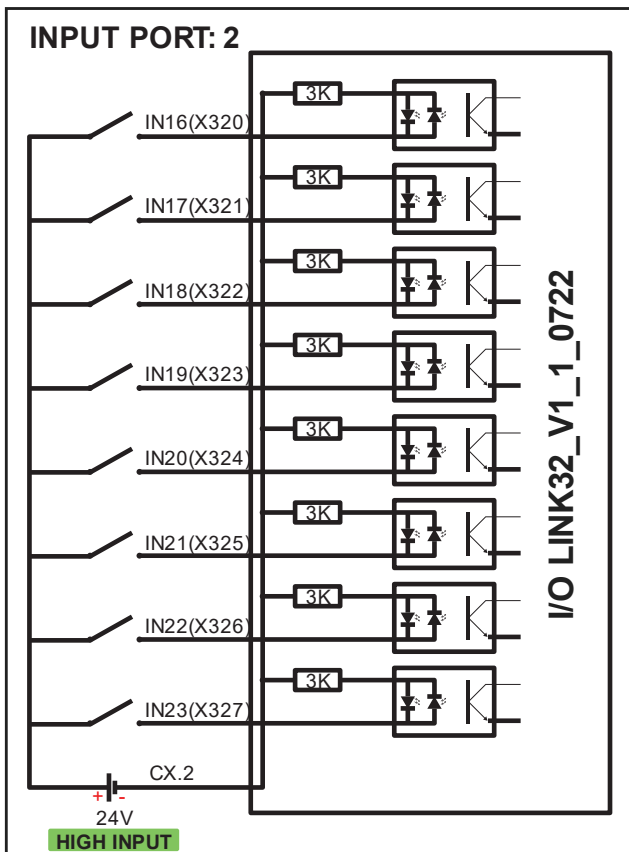
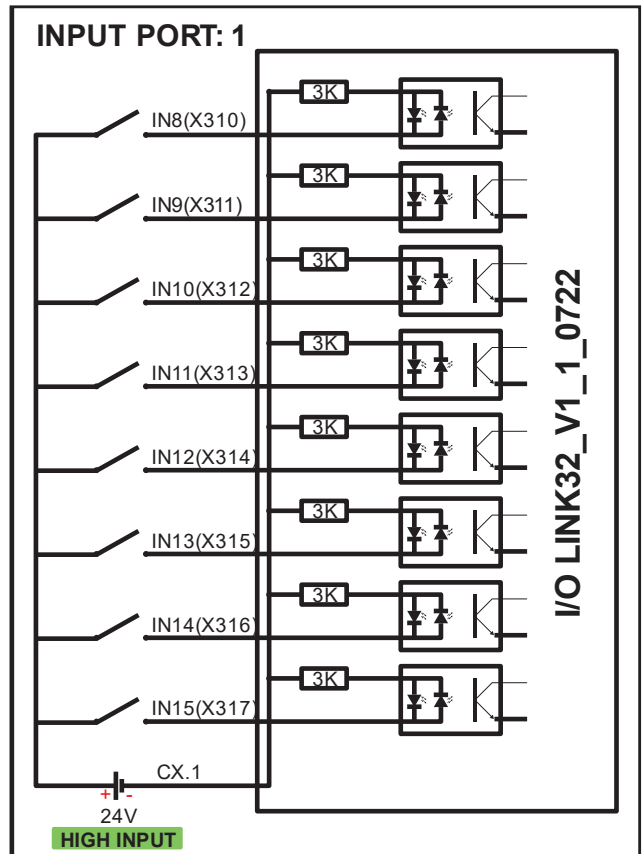
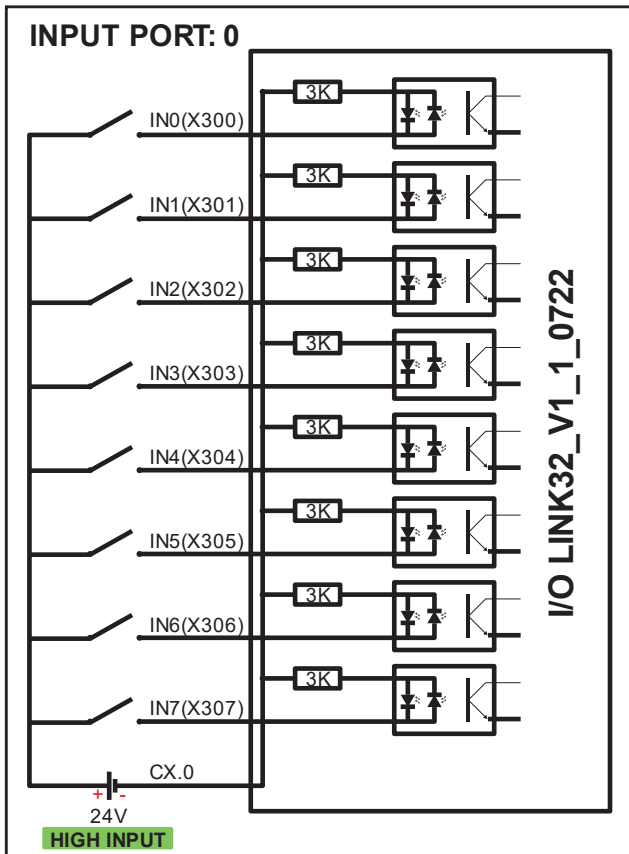

Figure 2-19. I/O link 32_v1.1_0722 board connection port

2.6.1 I/O LINK BOARD - INPUT PORT (LOW INPUT)



2.6.2 I/O LINK BOARD – INPUT PORT (HIGH INPUT)



2.6.3 I/O LINK BOARD - OUTPUT PORT

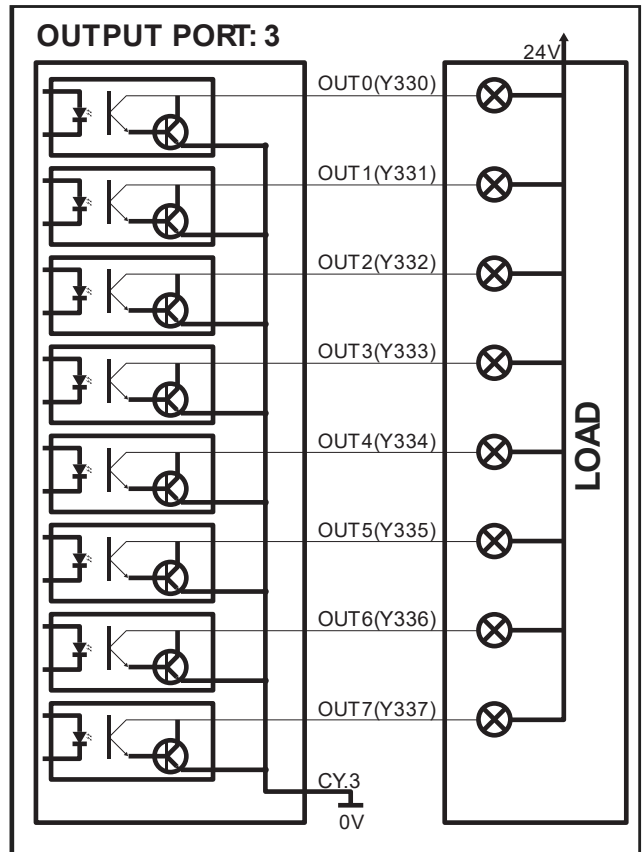
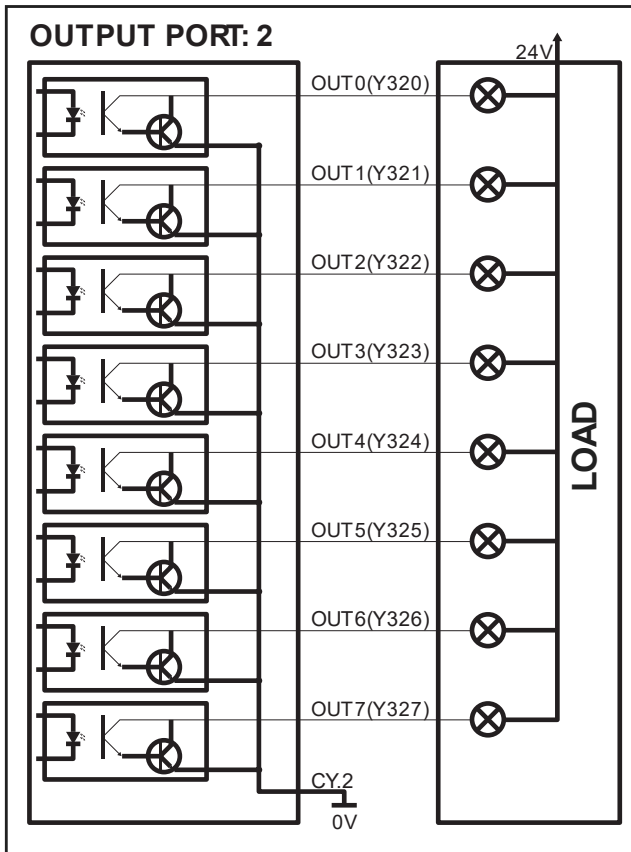
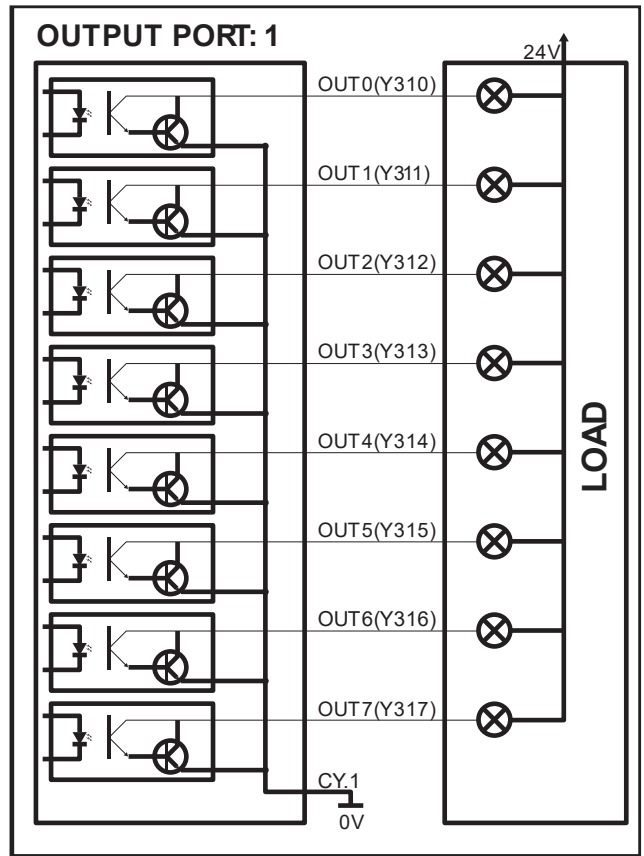
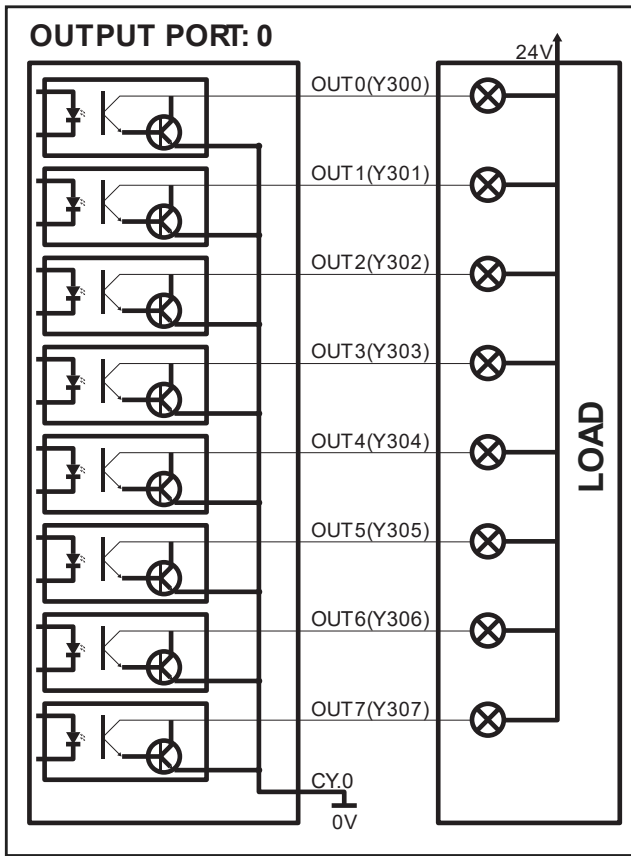

Note:

- RS485/I/O Link cable recommend using the cable have shield wire to against noise signals (Refer the image below)



Figure 2-20. I/O link cable using shield wire and be soldered to the controller

2.7 MPG HANDWHEEL WIRING DIAGRAM

2.7.1 4 AXIS TYPE – DIFFERENTIAL OUTPUT SIGNAL

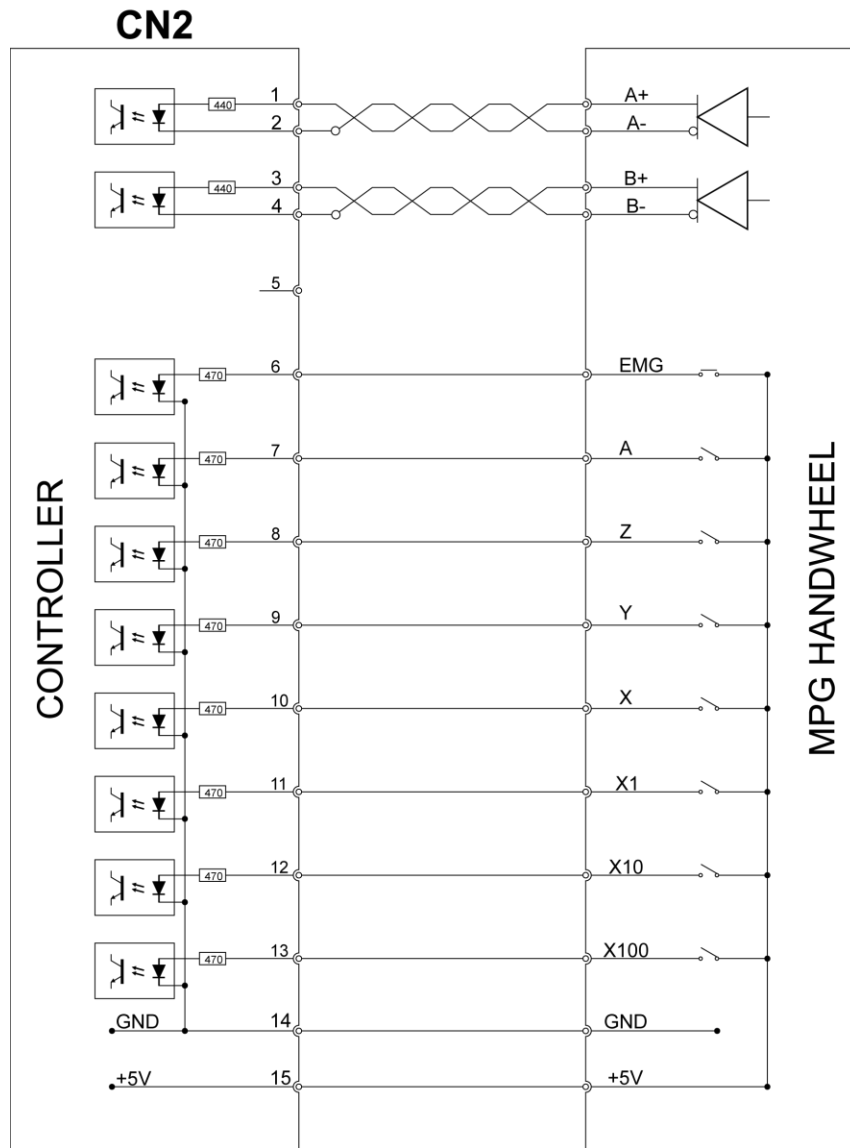

Figure 2-21. 4 axis MPG handwheel with differential output signal & EMG button

2.7.2 6 AXIS TYPE – DIFFERENTIAL OUTPUT SIGNAL

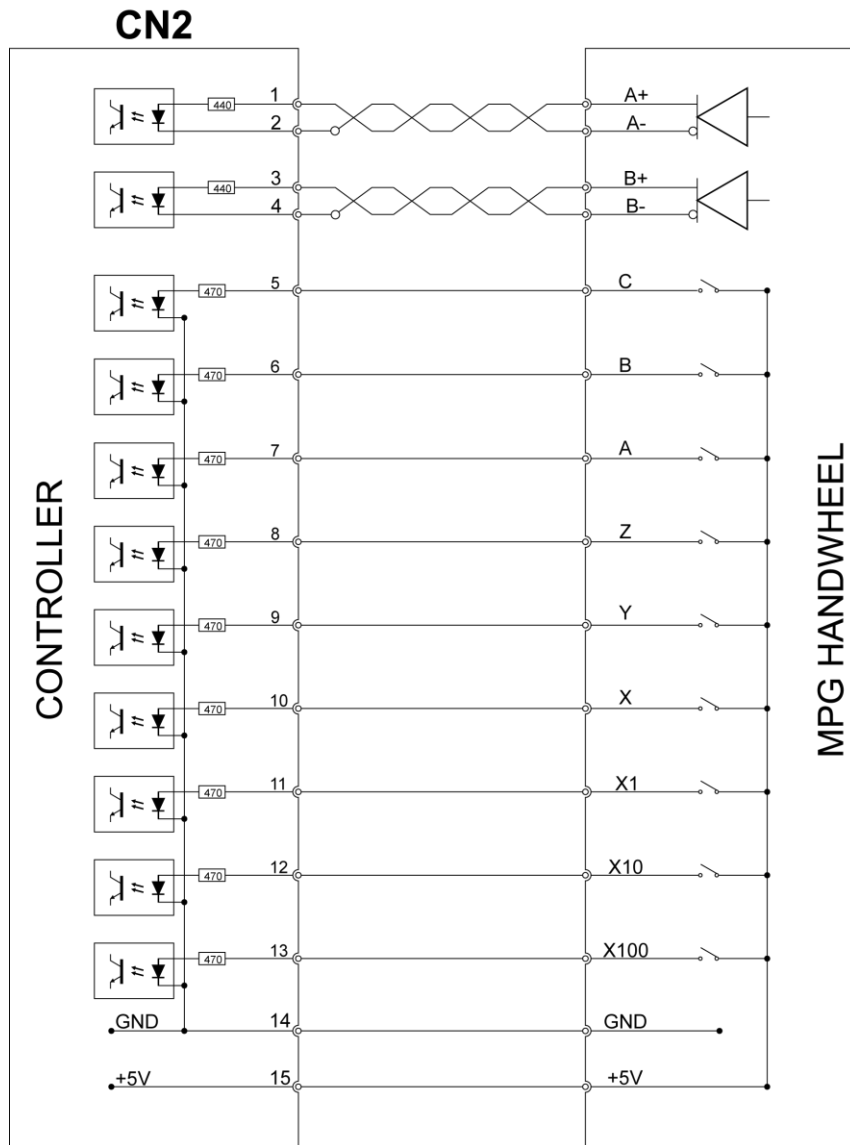

Figure 2-22. 6 axis MPG handwheel with differential output signal & EMG button

2.7.3 4 AXIS TYPE – NPN OUTPUT SIGNAL

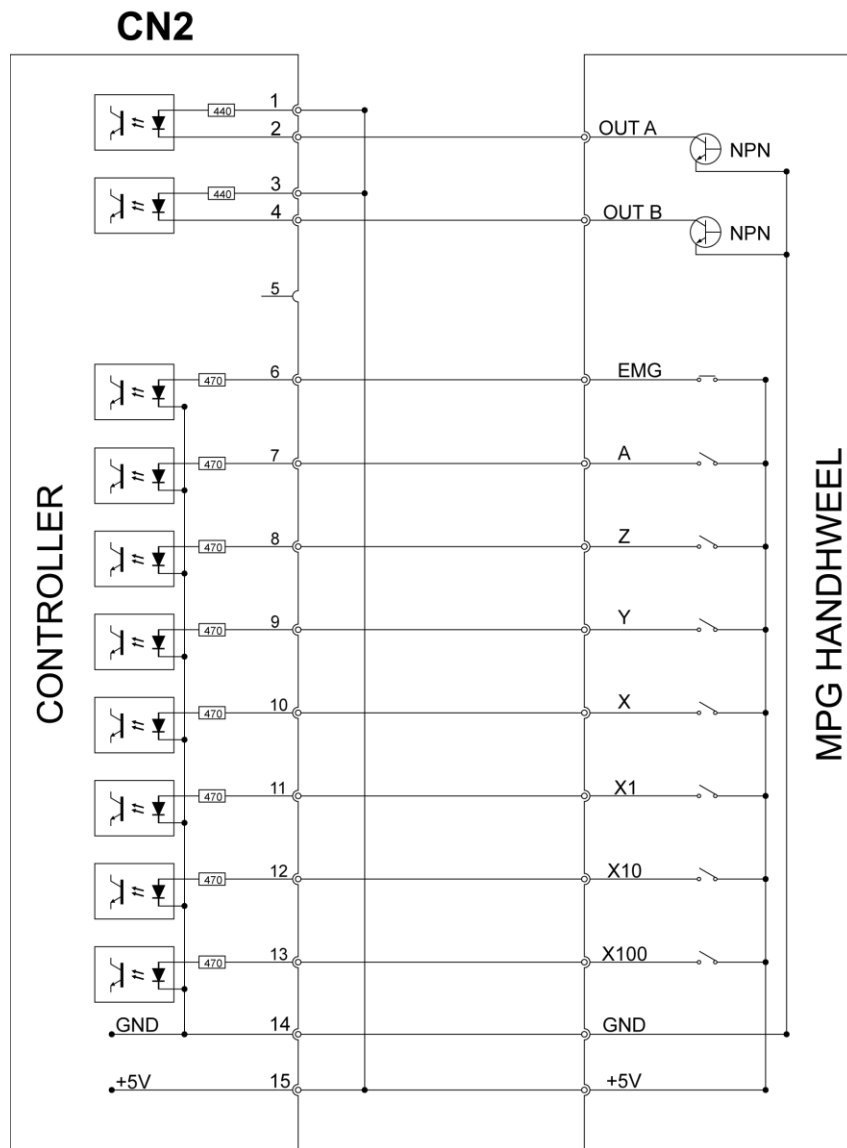

Figure 2-23. 4 axis MPG handwheel with NPN output signal

2.7.4 6 AXIS TYPE – NPN OUTPUT SIGNAL

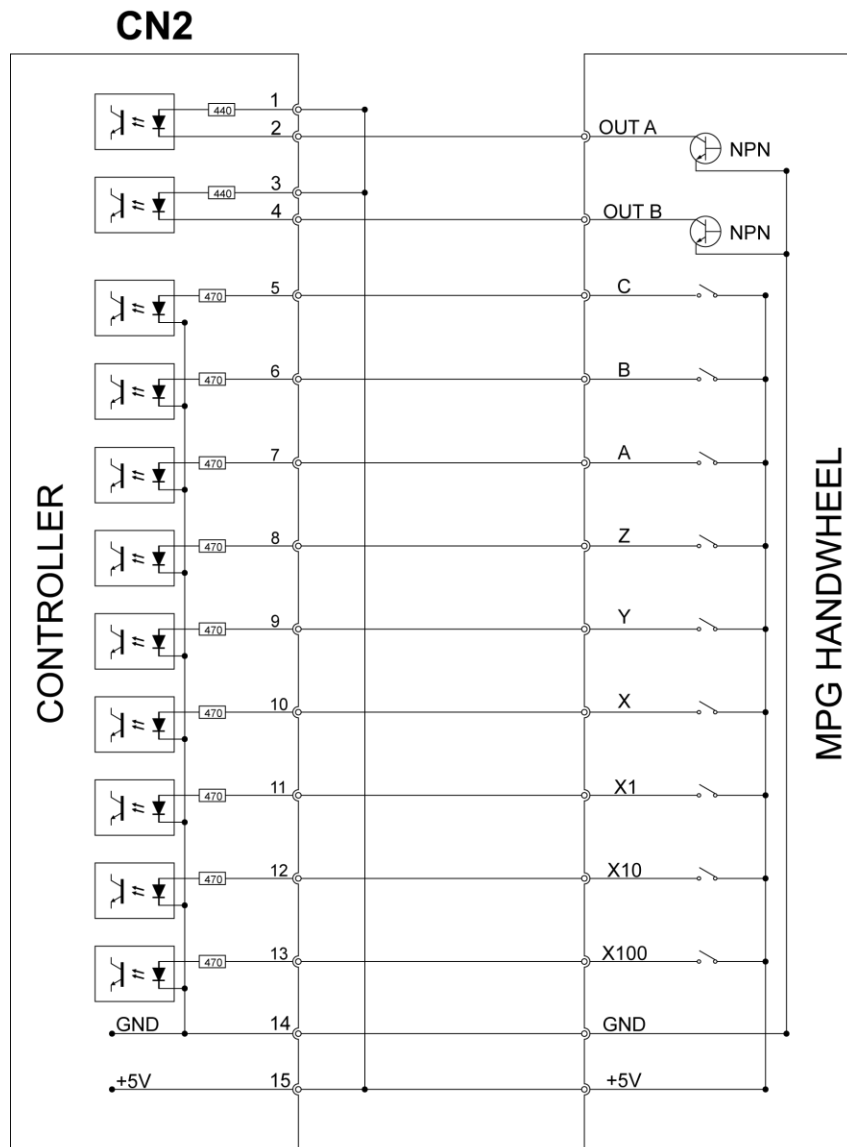

Figure 2-24. 6 axis MPG handwheel with NPN output signal

2.7.5 4 AXIS TYPE – PNP OUTPUT TYPE

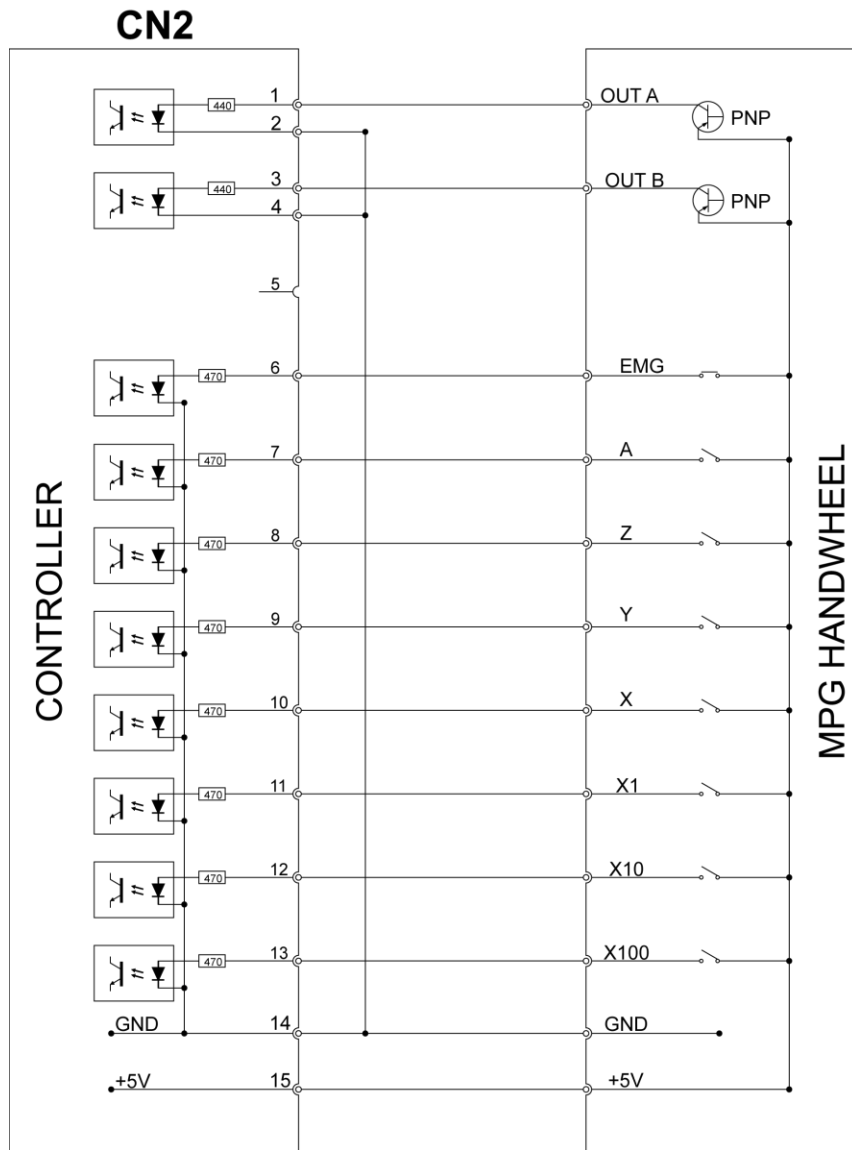

Figure 2-25. 4 axis MPG handwheel with PNP output signal

2.7.6 6 AXIS TYPE – PNP OUTPUT TYPE

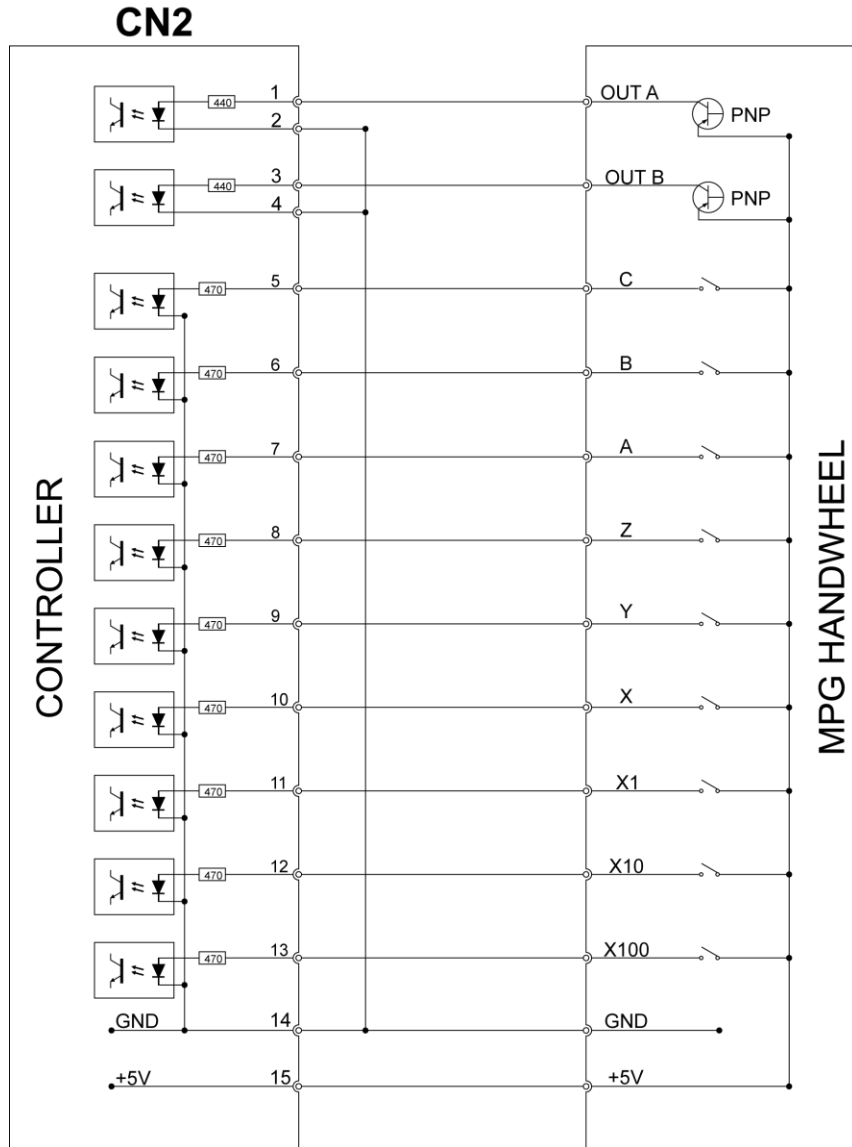

Figure 2-26. 6 axis MPG handwheel with PNP output signal

2.8 HOME SWITCH WIRING DIAGRAM

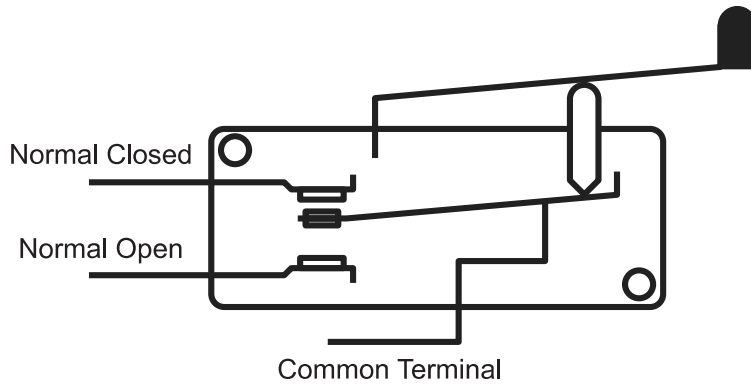
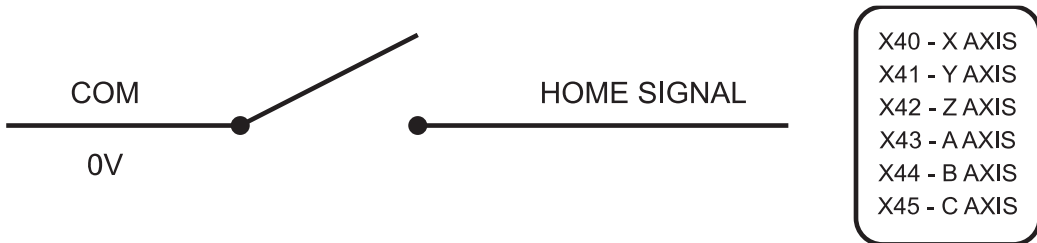

Figure 2-27. Home switch structure

2.8.1 PNP WIRING



2.8.2 NPN WIRING



2.9 REFERENCE CONNECTION PORT

2.9.1 AXIS CONTROL

DESCRIPTION	TERMINAL
X axis	PUL (1+) PUL (1-) DIR (1+) DIR (1-)
Y axis	PUL (2+) PUL (2-) DIR (2+) DIR (2-)
Z axis	PUL (3+) PUL (3-) DIR (3+) DIR (3-)
A axis	PUL (4+) PUL (4-) DIR (4+) DIR (4-)
B axis	PUL (5+) PUL (5-) DIR (5+) DIR (5-)
C axis	PUL (6+) PUL (6-) DIR (6+) DIR (6-)

2.9.2 INPUT SIGNAL

DESCRIPTION	TERMINAL
Home switch (X axis)	X40
Home switch (Y axis)	X41
Home switch (Z axis)	X42
Home switch (A axis)	X43
Home switch (B axis)	X44
Home switch (C axis)	X45
Hard limit X+	X46
Hard limit X-	X47
Hard limit Y+	X50
Hard limit Y-	X51

Hard limit Z+	X52
Hard limit Z-	X53
Start button	X54
Hold button	X55
Tool length sensor	X56 (Probe signal) X57 (Probe limit)
Alarm X driver	X60
Alarm Y driver	X61
Alarm Z driver	X62
Alarm A driver	X63
Alarm B driver	X64
Alarm C driver	X65
Spindle alarm	X66
Emergency Switch	X67

2.9.3 OUTPUT SIGNAL

DESCRIPTION	TERMINAL
Servo-ON	Y40
Spindle forward	Y41
Coolant-ON	Y42
Air pressure	Y43
Indicator light	Y44
Alarm light	Y45
START button light	Y46
FEEDHOLD button light	Y47

2.9.4 OTHER DEVICES

DESCRIPTION	TERMINAL
Power supply	CN1
Inverter	CN4
I/O link board Communication	CN3
MPG handwheel	CN5



CHAPTER 3.

OPERATION INTERFACE



3.1 MAIN PAGE

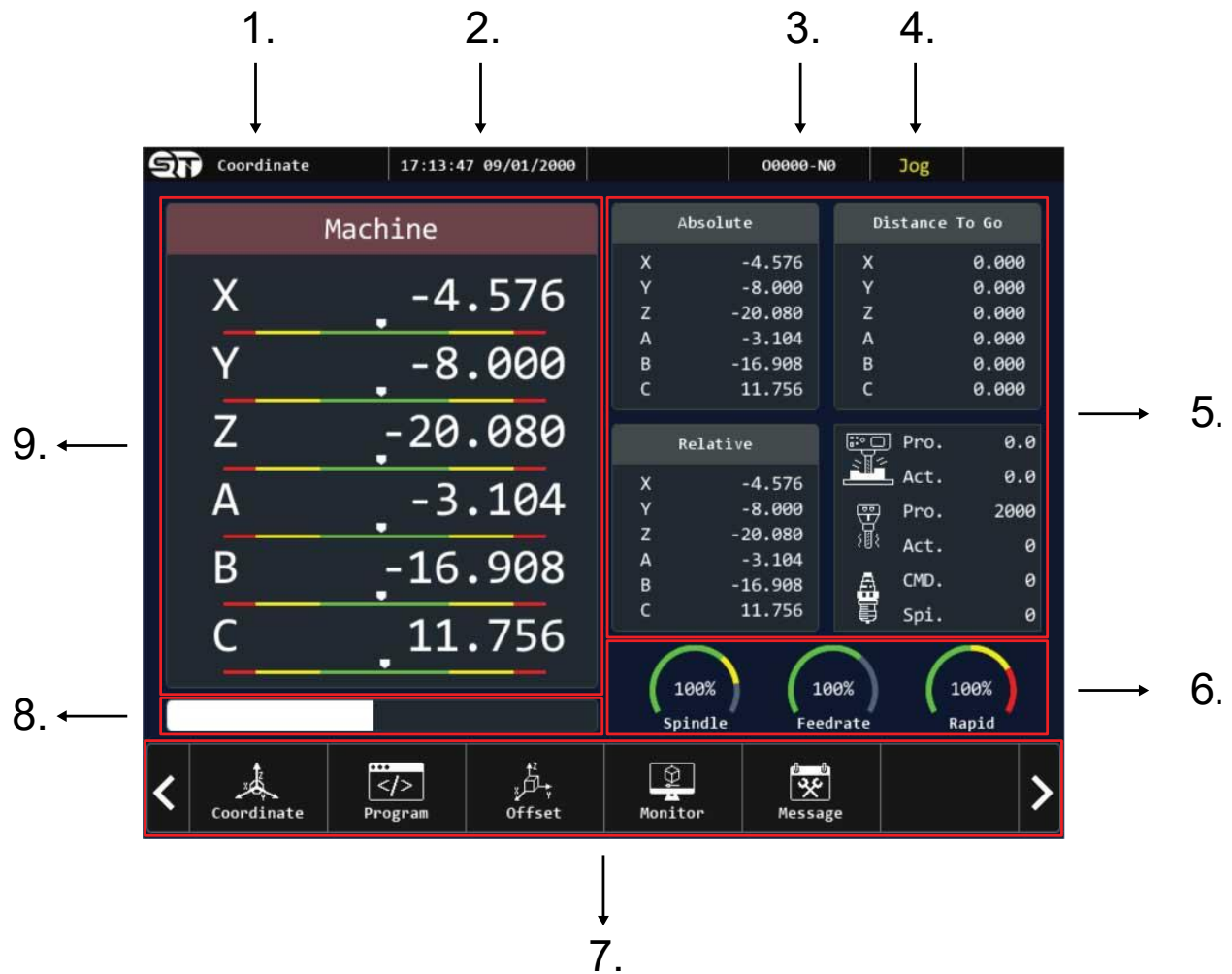

Figure 3-1. ASTRO 6AH controller main screen

MODEL	ASTRO 6AH
1	Screen name
2	Date & Time information
3	Program name
4	Operation mode
5	Coordinate systems, Feedrate, Spindle speed in program and in actual, current tool in spindle
6	Spindle, Rapid, Feedrate speed percent
7	Function bar
8	Data manual input
9	Machine coordinate system

Note:

- **Distance to go:** The remaining distance that the machine needs to move to complete a command or machining program.
- **Absolute coordinate system:** It is a coordinate system used to determine the position of the cutting tool based on a fixed reference point.

3.2 COORDINATE PAGE

On the coordinate page, the users can view and get the information of machine and coordinate systems. Including: Absolute coordinate systems, Relative coordinate systems and Distance to go values.

Coordinate features:

- **Switch screen:** Switching coordinate system display screen
- **Half:** Divide the Specified axis in relative coordinate system by 2
- **Zero:** Return the Specified axis to 0 position in relative coordinate system
- **Zero all:** Return all axis to 0 position in relative coordinate system

Model: ASTRO 6AH controller

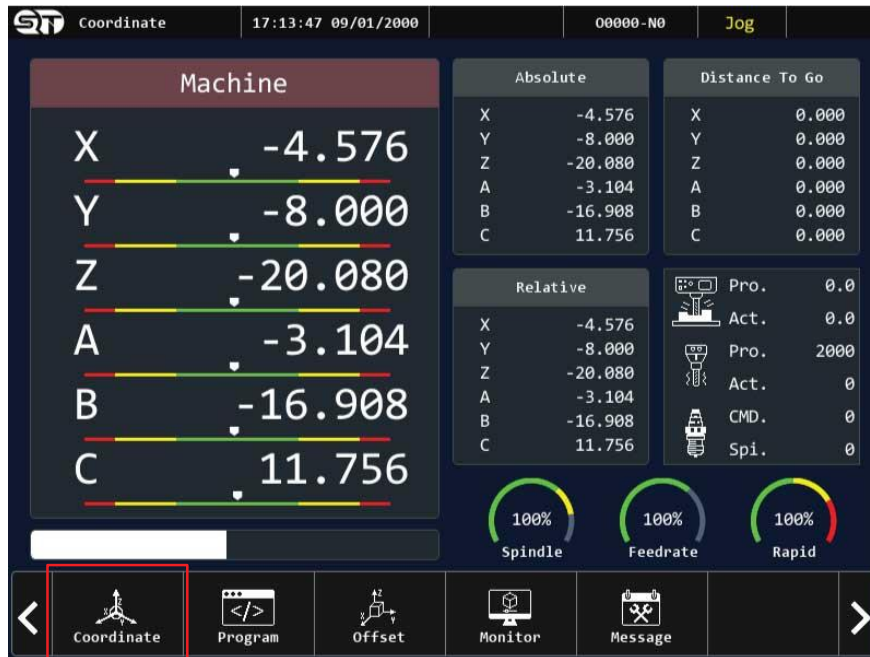

Figure 3-2. Coordinate page

Coordinate page instruction parts:

- Switching display coordinate systems **(3.2.1)**
- Divide the coordinate of Specified axis in relative position by 2 **(3.2.2)**
- Returns Specified axis in relative position to 0 position **(3.2.3)**

3.2.1 SWITCH SCREEN

Description Images
 Model: ASTRO 6AH

The screenshot shows the 'Coordinate' screen with the following data:

Machine		Absolute		Distance To Go	
X	-4.576	X	-4.576	X	0.000
Y	-8.000	Y	-8.000	Y	0.000
Z	-20.080	Z	-20.080	Z	0.000
A	-3.104	A	-3.104	A	0.000
B	-16.908	B	-16.908	B	0.000
C	11.756	C	11.756	C	0.000

Relative coordinates and other parameters are also displayed in the lower right section of the screen.

The bottom navigation bar includes buttons for Coordinate, Program, Offset, Monitor, and Message. The 'Coordinate' button is highlighted with a red box.

Below the screen is a row of physical buttons. A hand icon points to the first button on the left, which corresponds to the 'Coordinate' button on the screen.

The second screenshot shows the same 'Coordinate' screen, but the 'Full Screen' button in the bottom navigation bar is highlighted with a red box.

Below this screen is another row of physical buttons. A hand icon points to the first button on the left, which corresponds to the 'Full Screen' button on the screen.

Memo
 Model: ASTRO 6AH

Step 1:

From the main screen, select COORD button.

Step 2:

Press FULL SCREEN button.

Note:

Coordinate systems arrangement:
 Machine → Absolute → DIS → Relative

3.2.2 HALF

Description Images

Model: ASTRO 6AH



Memo

Model: ASTRO 6AH

Step 1:

Press SWITCH button to switch to RELATIVE coordinate system.

Step 2:

Select the axis you want to divide the coordinate by 2 in relative coordinate system and select HALF.

3.2.3 ZERO-ZERO ALL

Description Images

Model: ASTRO 6AH

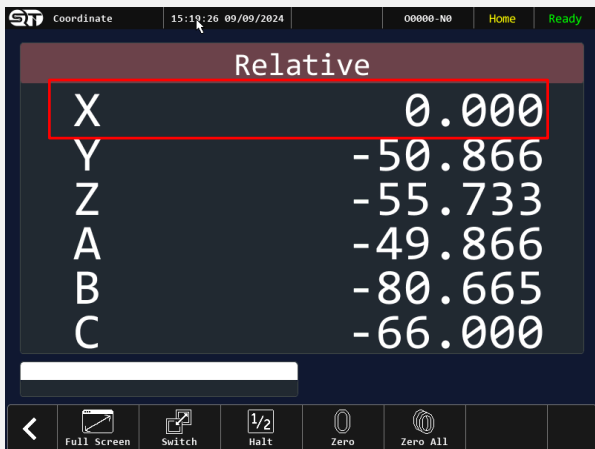
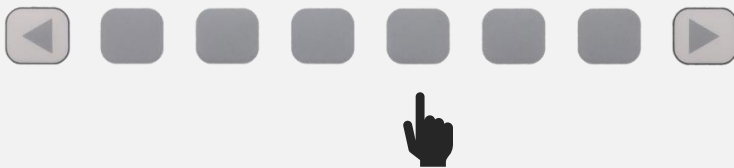
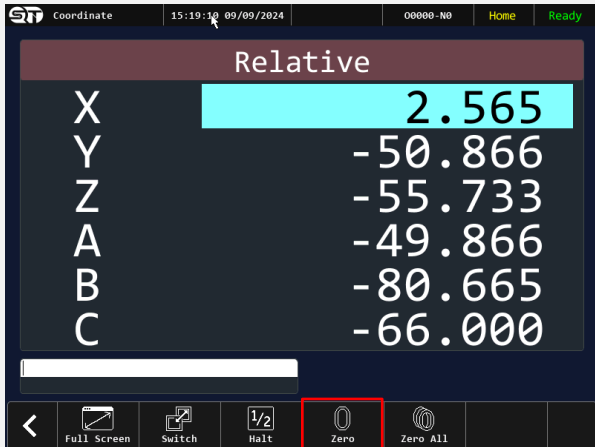

Memo

Model: ASTRO 6AH

Step 1:

In RELATIVE coordinate system. Select the axis that you want to interact and press ZERO button.

Step 2:

The coordinate of the axis will be divided by 2 automatically.

Description Images

Model: ASTRO 6AH

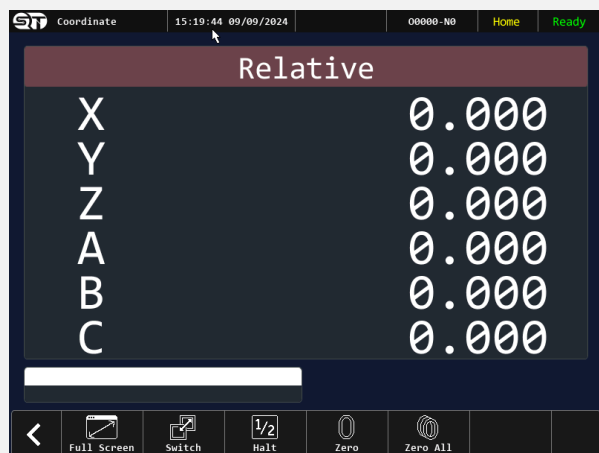
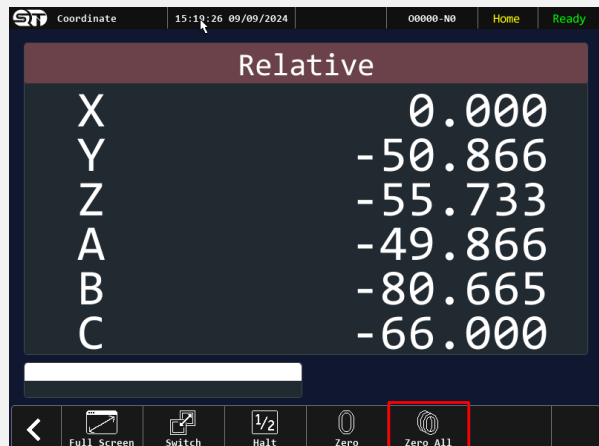

Memo

Model: ASTRO 6AH

Step 3: (ZERO ALL)

At relative coordinate system. Press ZERO ALL button.

Step 4:

The coordinate of all axis will return to 0 value..

3.3 PROGRAM PAGE

On this page allows the users to store, edit and execute program

Program features:

- **Execute:** Execute program
- **New file:** Create a new file
- **Open file:** Open a file
- **Go to line:** Go to Specified line of program
- **Search:** Search for an object in program
- **Replace:** Replace an existing object with another object
- **Delete line:** Clear code line
- **Copy from:** Select object at current location to duplicate
- **Copy to:** Specified the location where to paste file
- **Paste:** confirm and duplicate the file

Model: ASTRO 6AH controller



Figure 3-3. Program page

Program page instruction parts:

- Copy data from USB to controller **(3.3.1)**
- Execute program **(3.3.2)**
- Go to any command line **(3.3.3)**
- Search for an object in program-replace object **(3.3.4)**
- Delete a command line **(3.3.5)**
- Copy and paste **(3.3.6)**

3.3.1 COPY DATA FROM USB TO CONTROLLER

Description Images

Model: ASTRO 6AH



01:23:30 13/06/2000 00000-N0 Jog Ready

0:/6-CAT BIEN D4.NC 131541 bytes

```
%
011110(6-CAT BIEN D4)

G0 G90 X-99.875 Y130.79 S3200 M3
Z12. M8
Z6.
G1 Z3.603 F500.
Y127.79 F51111.
G3 X-97.875 Y125.79 R2.
G2 X-50.366 Y118.598 R160.512
X-40.998 Y114.382 R41.988
G1 X-33.809 Y110.036
G2 X-32.815 Y108.273 R2.06
G1 Y24.225
G2 X-33.811 Y22.461 R2.06
```

Execute New File Open File

Hand icon pointing to the 'Open File' button.



00:53:05 13/06/2000 00000-N0 Jog Ready

1:/gia cng/6-CAT BIEN D4.NC Size: 131541 bytes Date: 02/03/2023-10:41

System Disk	USB Disk
..	..
6- D6R1.NC	6- D6R1.NC
C3_D1S_3D_0.005.NC	6-CAT BIEN D4.NC
	POTKET-D10.NC
	VET_D10.NC

Sel/DeSel Sel/DeSel All Open File Copy Delete New Folder

Hand icon pointing to the 'Copy' button.

Memo

Model: ASTRO 6AH

Step 1:

Go to program screen and press OPEN FILE button.

Step 2:

Plugin USB drive to controller, then select program and press COPY button.

3.3.2 EXECUTE PROGRAM

Description Images

Model: ASTRO 6AH

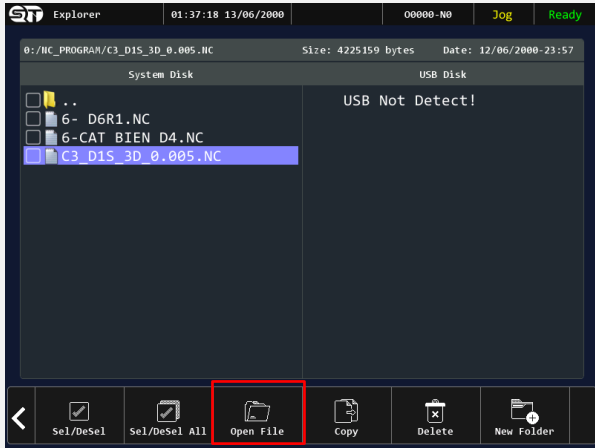
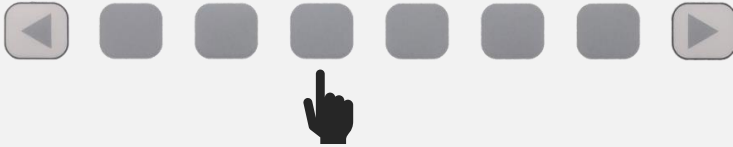
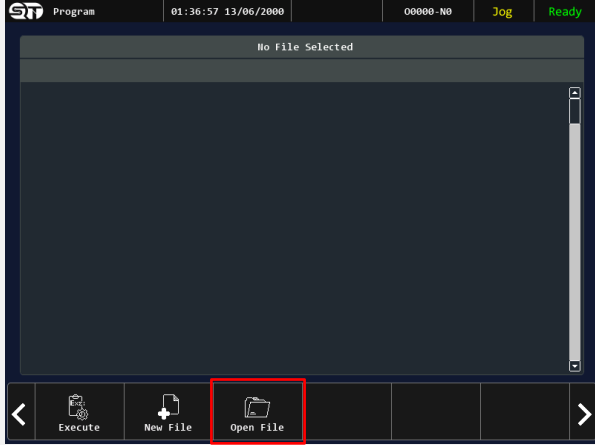

Memo

Model: ASTRO 6AH

Step 1:

Go to program screen and press OPEN FILE button.

Step 2:

Select program and press OPEN FILE button.

Description Images

Model: ASTRO 6AH

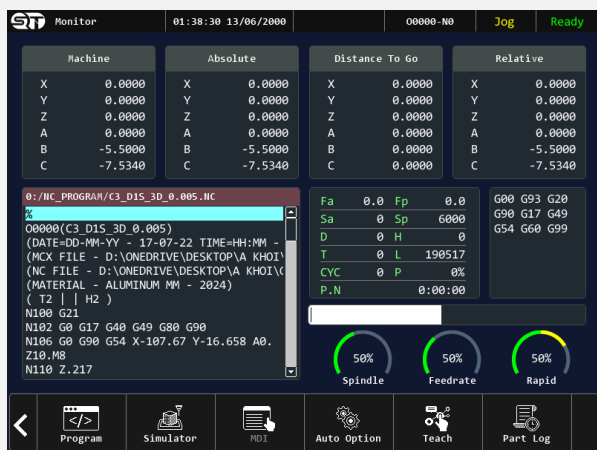
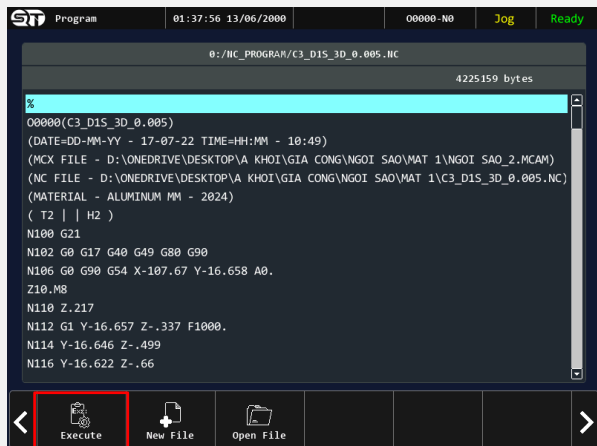

Memo

Model: ASTRO 6AH

Step 3:

Press EXCECUTE button.

Step 4:

Check program after executed.

3.3.3 GO TO ANY COMMAND LINE

Description Images

Model: ASTRO 6AH

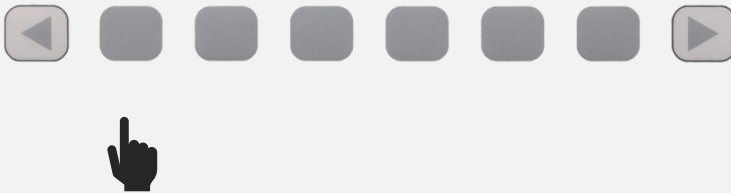
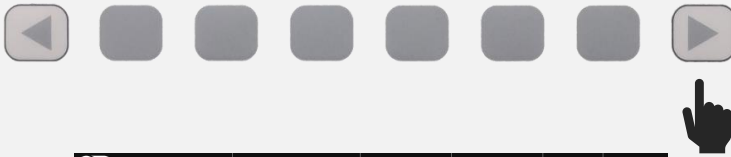
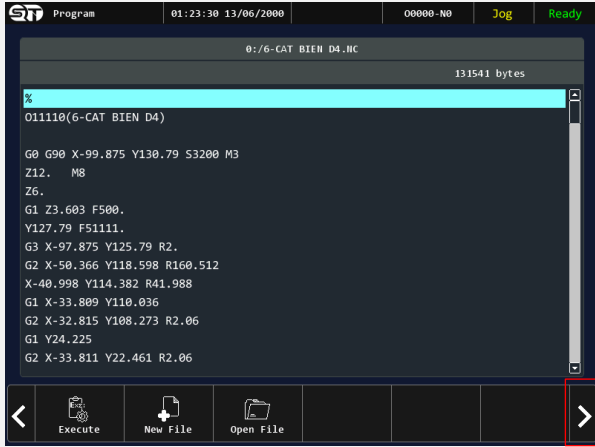

Memo

Model: ASTRO 6AH

Step 1:

Press the arrow button on the left to change to next page.

Step 2:

Press GO TO LINE button.

Description Images

Model: ASTRO 6AH

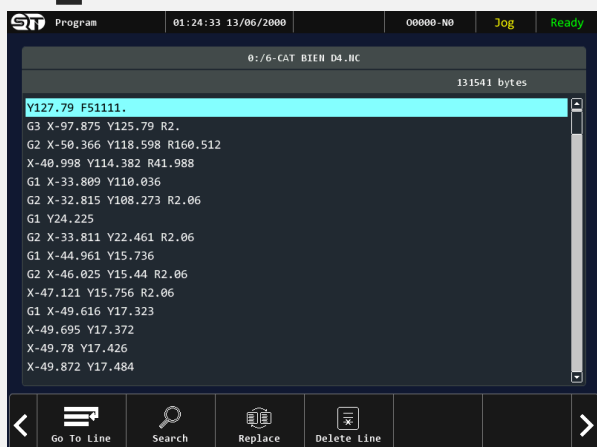
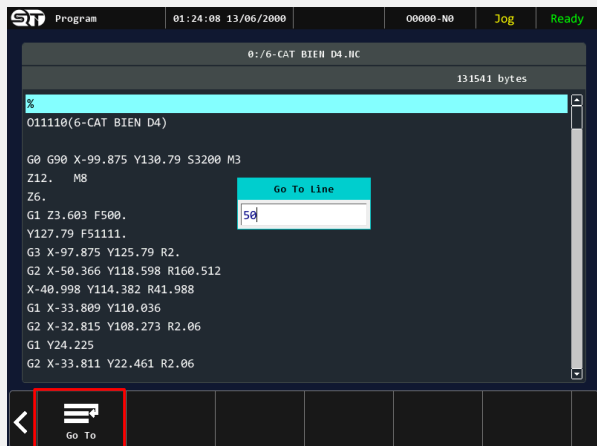

Memo

Model: ASTRO 6AH

Step 3:

Enter line number you want to go to and press GO TO button.

Step 4:

The controller will automatically jump to that command line.

3.3.4 SEARCH FOR AN OBJECT IN PROGRAM AND REPLACE

Description Images
Model: ASTRO 6AH

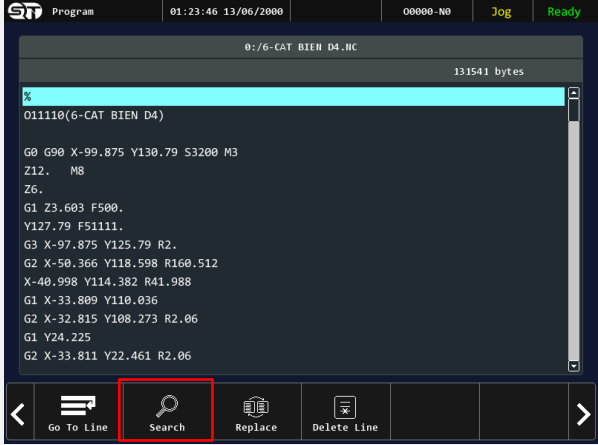

The screenshot shows the control panel interface. At the top, it displays 'Program', '01:23:46 13/06/2000', '00000-N0', 'Jog', and 'Ready'. The main display area shows the program name '0:/6-CAT BIEN D4.HC' and '131541 bytes'. Below this, the program code is visible, starting with '%', 'O11110(6-CAT BIEN D4)', and several G-code lines. At the bottom, there is a navigation bar with icons for 'Go To Line', 'Search', 'Replace', and 'Delete Line'. The 'Search' icon is highlighted with a red box, and a hand icon is shown pointing at it.

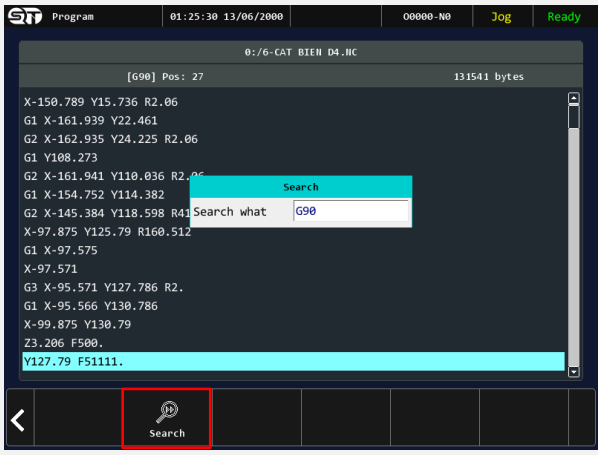

The screenshot shows the control panel interface after the search operation. The top status bar is the same. The main display area shows the program name and '131541 bytes'. Below this, the program code is visible, starting with 'X-150.789 Y15.736 R2.06'. A search dialog box is overlaid on the screen, showing 'Search what' and 'G90'. The 'Search' icon in the navigation bar is highlighted with a red box, and a hand icon is shown pointing at it.

Memo
Model: ASTRO 6AH

Step 1:
Press SEARCH button.

Step 2:
Enter object name and press SEARCH button.

Description Images

Model: ASTRO 6AH

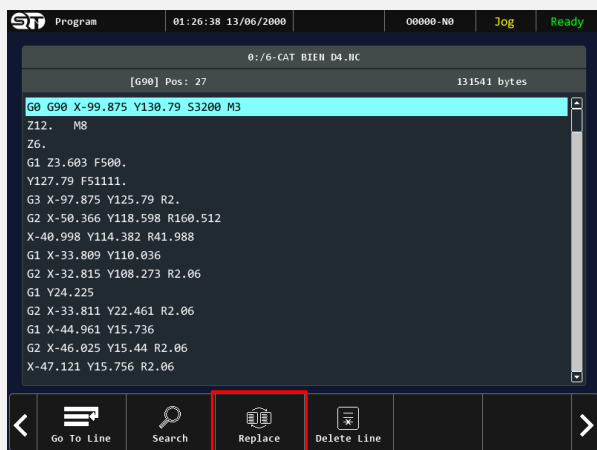
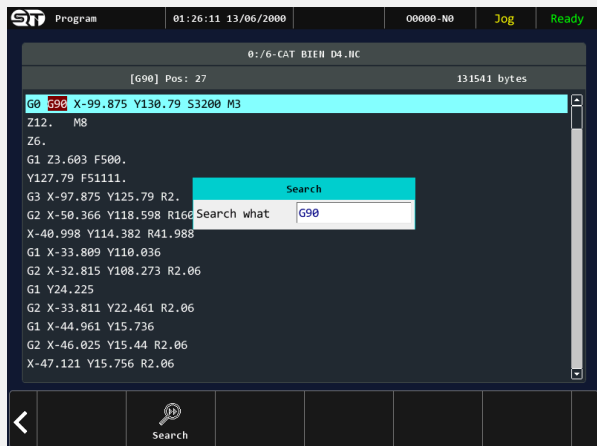

Memo

Model: ASTRO 6AH

Step 3:

If the object or value is existing in program. The controller will find and give the result.

Step 4 (Find & Replace):

Press REPLACE button.

Description Images

Model: ASTRO 6AH

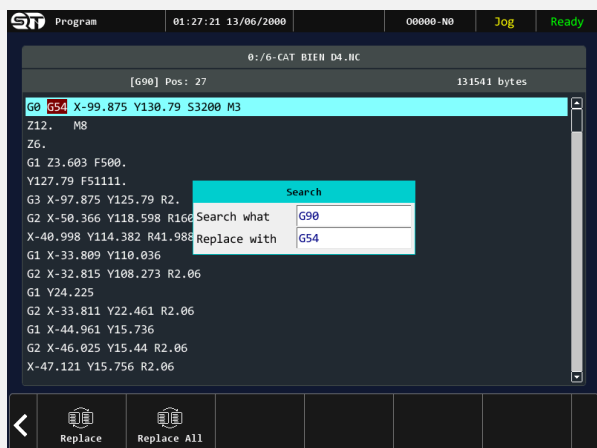
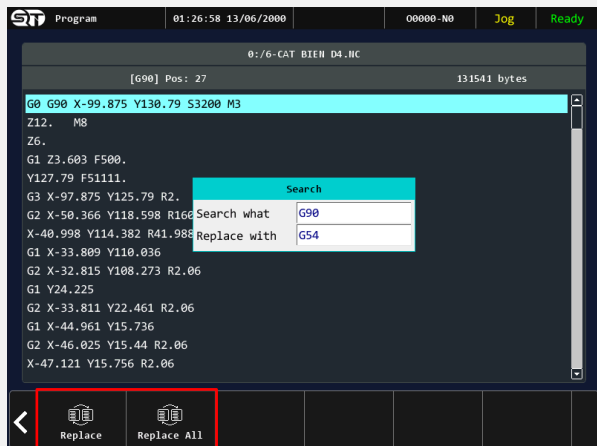

Memo

Model: ASTRO 6AH

Step 5:

Enter the object name you want to replace, enter the replacement object and press REPLACE or REPLACE ALL.

Note:

REPLACE: Replace only for one object

REPLACE ALL: Replace all object

3.3.5 DELETE A COMMAND LINE

Description Images

Model: ASTRO 6AH

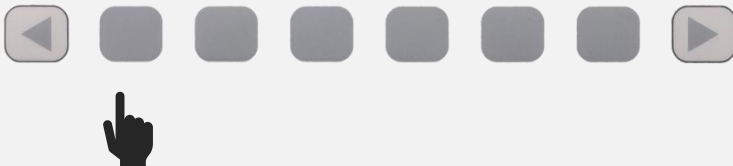
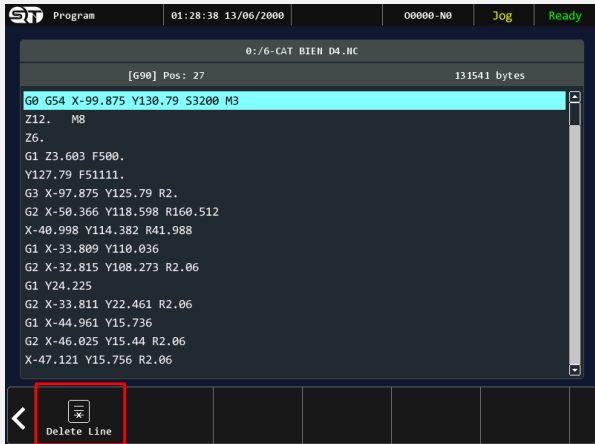
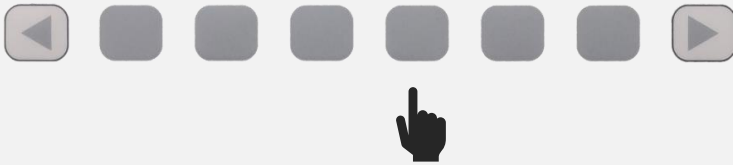
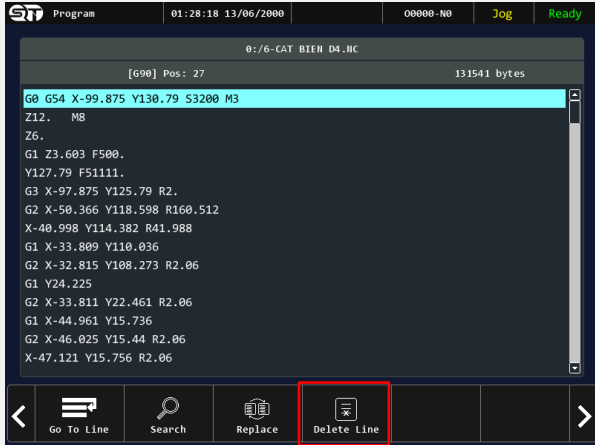

Memo

Model: ASTRO 6AH

Step 1:

Press DELETE LINE button.

Step 2:

Select command line you want to delete and press DELETE LINE button.

Description Images

Model: ASTRO 6AH

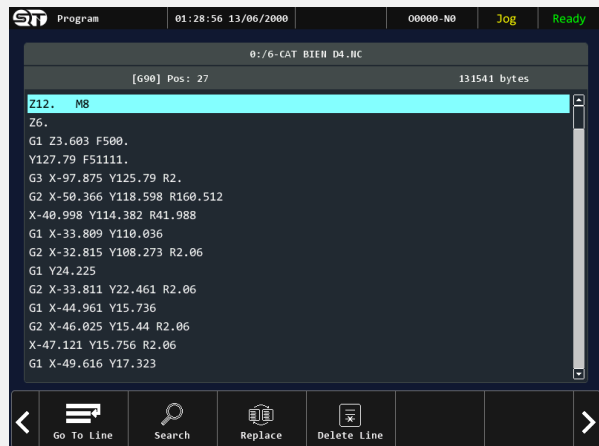

Memo

Model: ASTRO 6AH

Step 3:

Check the command line after being deleted.

3.3.6 COPY AND PASTE

Description Images

Model: ASTRO 6AH

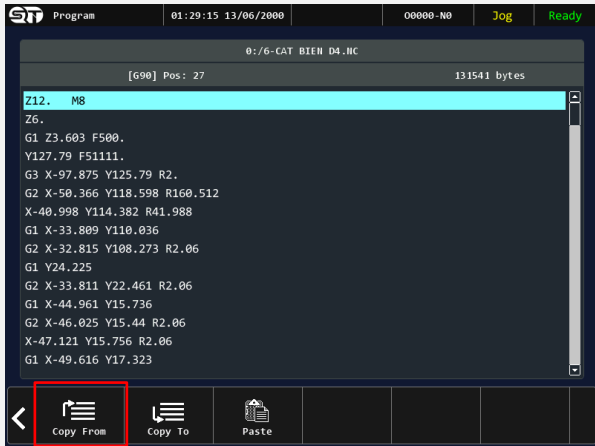

Memo

Model: ASTRO 6AH

Step 1:

Press the arrow button on the left to change to next page.

Step 2:

Select command line you want to copy and press COPY FROM button.

Description Images

Model: ASTRO 6AH

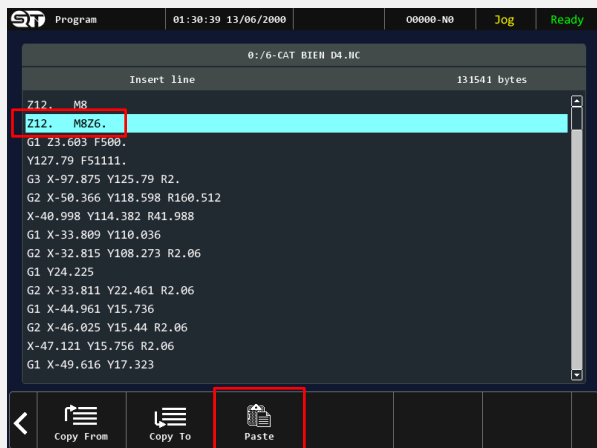
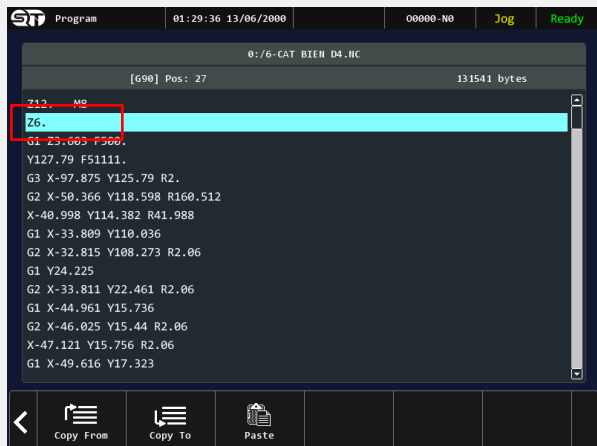

Memo

Model: ASTRO 6AH

Step 3:

Select where you want to paste and press COPY TO button.

Step 4:

Press PASTE button.

3.4 OFFSET PAGE

Here is the place for the users establish working values of workpiece as well as the height and diameter of cutting tool.

QS Controllers provide users with 6 coordinate system, including: G54, G55, G57, G58, G59 and 18 extended workpiece coordinate system from G59.1 (G54P7) to G59.12 (G54P18).

Offset features:

- **Work set:** Establish workpiece values
- **Tool set:** Establish the height, diameter of cutting tool
- **Tool NO:** Display table of the current tool in tool magazine
- **Apply AUX:** Assign the coordinate was being calculated in middle function to specified coordinate system
- **Apply MACH:** Assign the machine coordinates to specified coordinate system
- **Middle function:** Calculate the coordinate of the center point by 4 points of rectangle workpiece and 3 points of circle workpiece.

Model: ASTRO 6AH controller

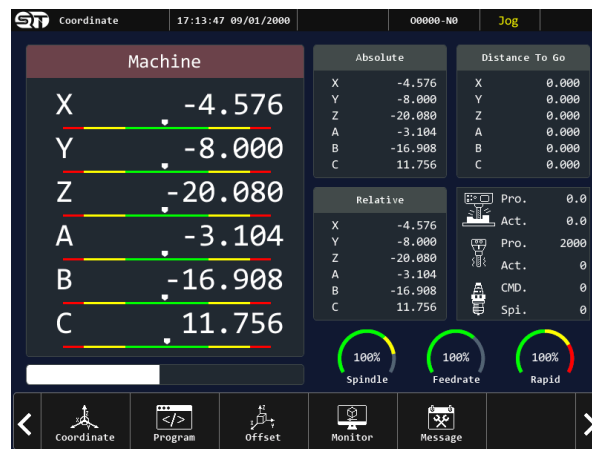

Figure 3-4. Offset page

Offset page instruction parts:

- Manual data input **(3.4.1)**
- Assign machine, auxiliary coordinates to specified coordinate system **(3.4.2)**
- Quickly get the center points of 4 points workpiece and 3 points workpiece **(3.4.3)**
- Tool set **(3.4.4)**

3.4.1 MANUAL DATA INPUT

Description Images
Model: ASTRO 6AH

The image shows two screenshots of the ST Offset page. The top screenshot shows the 'EXTERNAL SHIFT' section with 'G54 (G54P1)' selected. The 'X' coordinate is highlighted with a red box. Below the screenshot is a diagram of a control panel with a hand icon pointing to the right arrow button. The bottom screenshot shows the same page with the 'X' coordinate value changed to '20.456' and highlighted with a red box. Below this screenshot is a button labeled 'Enter' with a left arrow icon.

EXTERNAL SHIFT		G54 (G54P1)	
X	0.000	X	0.000
Y	0.000	Y	0.000
Z	0.000	Z	0.000
A	0.000	A	0.000
B	0.000	B	0.000
C	0.000	C	0.000

MGP SHIFT		G55 (G54P2)	
X	0.000	X	0.000
Y	0.000	Y	0.000
Z	0.000	Z	0.000
A	0.000	A	0.000
B	0.000	B	0.000
C	0.000	C	0.000

Machine	
X	74.979
Y	106.397
Z	0.000
A	55.999
B	-25.133
C	0.000

Auxiliary	
X	0.000
Y	0.000
Z	0.000
A	0.000
B	0.000
C	0.000

20.456

Enter

Memo

Model: ASTRO 6AH

Step 1:

Select the coordinate system(G54) by press the arrow buttons on control panel.

Step 2:

Enter values to the axis and press ENTER button to confirm.

3.4.2 ASSIGN MACHINE, AUXILIARY COORDINATES TO SPECIFIED COORDINATE SYSTEM

Description Images

Model: ASTRO 6AH

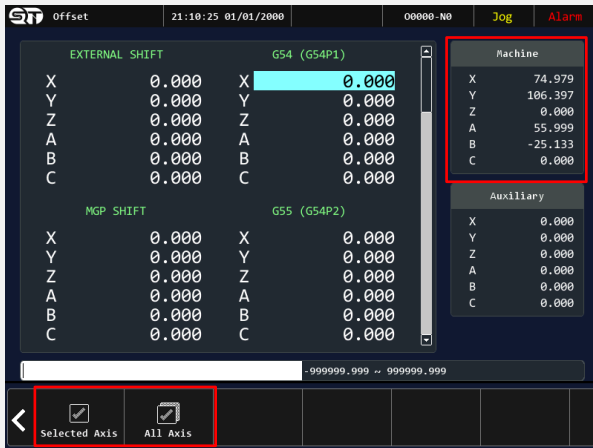
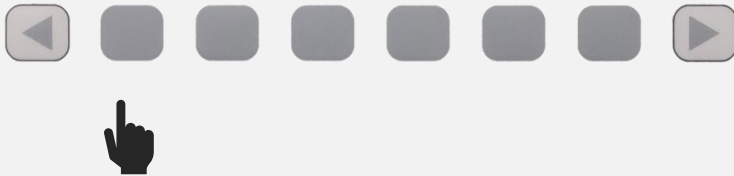

Memo

Model: ASTRO 6AH

Step 1:

Select the axis and press APPLY MACH button.

Step 2:

SELECTED AXIS: Assign the coordinate of the corresponding axis to specified axis.

ALL AXIS: Assign all the machine coordinates to the specified coordinate system.

Description Images

Model: ASTRO 6AH

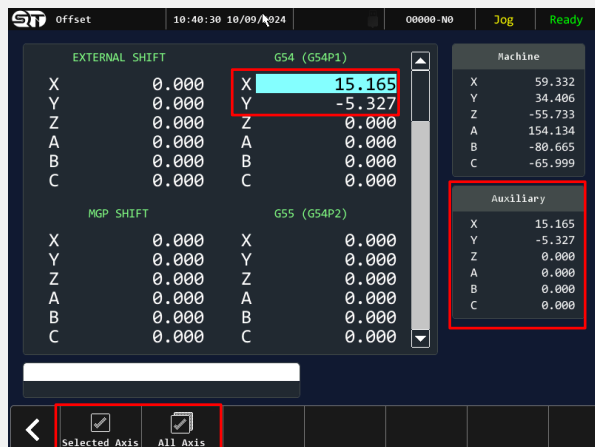
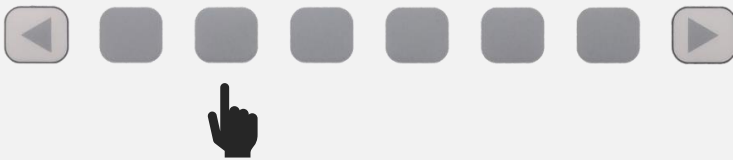
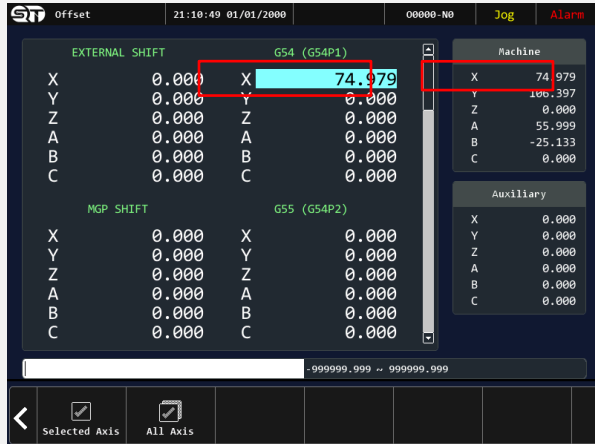

Memo

Model: ASTRO 6AH

Step 3:

Check the coordinate after being assigned.

Note:

Make the same steps above when assigning auxiliary coordinate (APPLY AUX). Select APPLY AUX instead APPLY MACH

AUX coordinate will be calculated in MIDDLE FUNCTION, refer at **(3.4.3)** below

3.4.3 CALCULATE THE CENTER POINT OF 4 POINTS AND 3 POINTS WORKPIECE

Description Images

Model: ASTRO 6AH

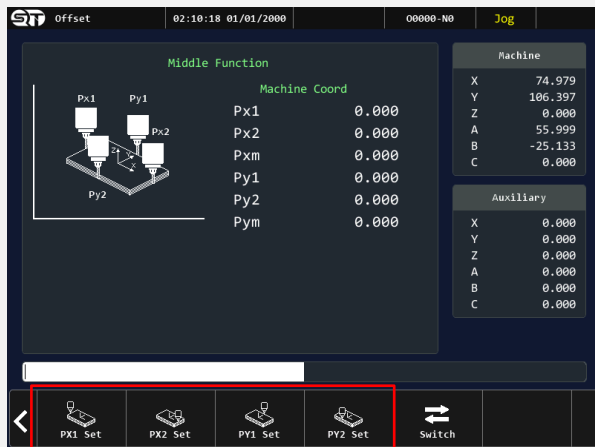

Memo

Model: ASTRO 6AH

Four-point workpiece

Step 1:

Press MIDDLE FUNCTION button.

Step 2:

Move to reach 4 edges (Px1,Px2,Py1,Py2). Then establish the position values of the workpiece base on the description image. When you complete the coordinate of the center point will be calculated and displayed at PXM, PYM and Auxiliary coordinate

Description Images

Model: ASTRO 6AH

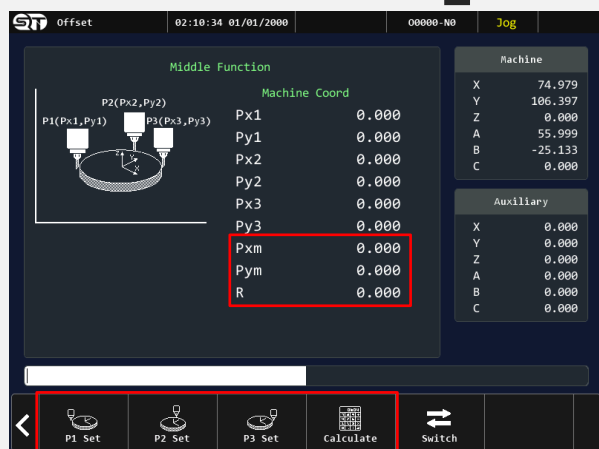
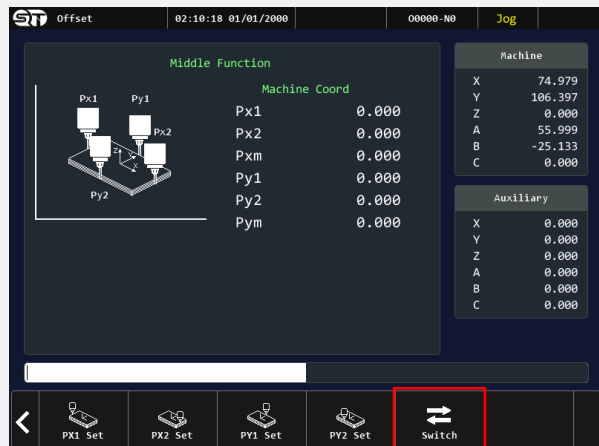

Memo

Model: ASTRO 6AH

Three-point workpiece

Step 1:

Press SWITCH button on the left to move to next page.

Step 2:

Move to reach 3 points of circle workpiece (P1,P2,P3). Then establish the position values base on the description image. When you complete. Press CALCULATE button. The coordinate of the center point will be displayed at (PXM,PYM,R), R is the radius of workpiece.

3.5 MONITOR PAGE

At the monitor screen, the users can easy get the information, coordinate systems of machine such as: Program name, Operation mode, federate, spindle speed percent...

Monitor features:

- **Program:** quick access to system disk
- **Simulator:** simulate the working program
- **MDI:** manual data input
- **Auto Option:** safety feature
 - o Allow to run form any command line in program
 - o Continue the working process from the last command line if the machine was suddenly stopped before
 - o Automatically create a secondary program to activate all necessary G-code before jumping to the last command that was stopped

Model: ASTRO 6AH controller

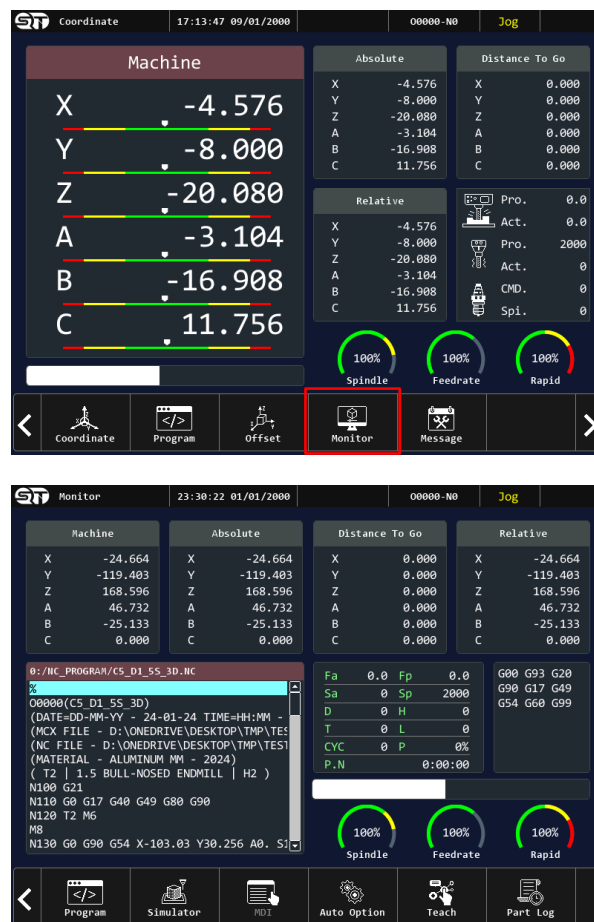

Figure 3-5. Monitor page

Monitor instruction parts:

- Toolpath simulation **(3.5.1)**
- MDI mode **(3.5.2)**
- Auto features **(3.5.3)**
 - o Start program from any command line **(3.5.3.1)**
 - o Continue the working process from the last stopped command **(3.5.3.2)**
- Working history **(3.5.4)**

3.5.1 TOOLPATH SIMULATION

Description Images
Model: ASTRO 6AH

Memo
Model: ASTRO 6AH

Step 1:
After executed the program, at the monitor screen. Press SIMULATOR button.

Step 2:
Waiting for the simulation process.
SET WORK: Dimension of workpiece
AUTO SCALE: scale the shape fit to screen
TOOL MODE: simulate the program by multiple view mode such as: Milling, Engraving 2D – Milling, Engraving 3D.
INFORMATION: The maximum and minimum travel of workpiece

Description Images

Model: ASTRO 6AH

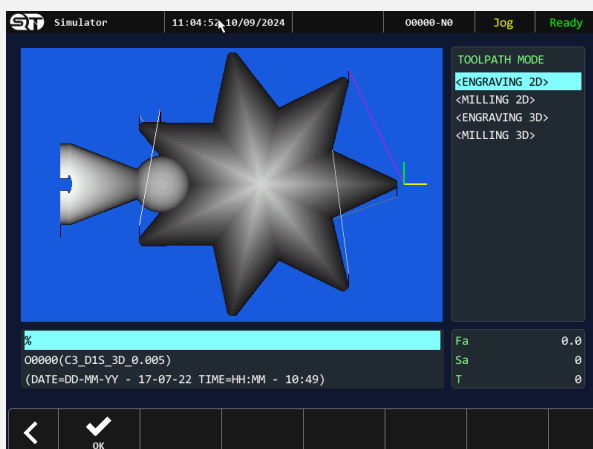
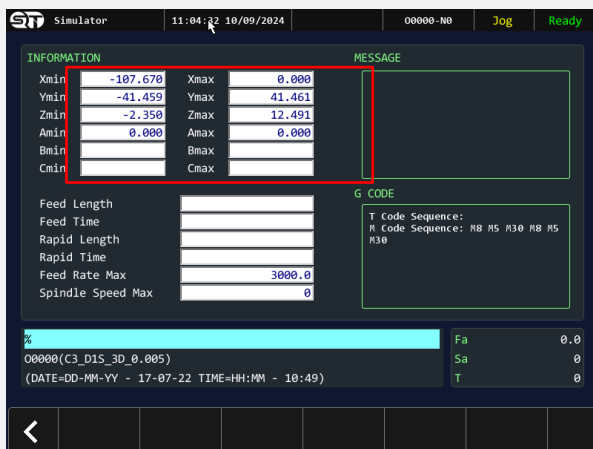
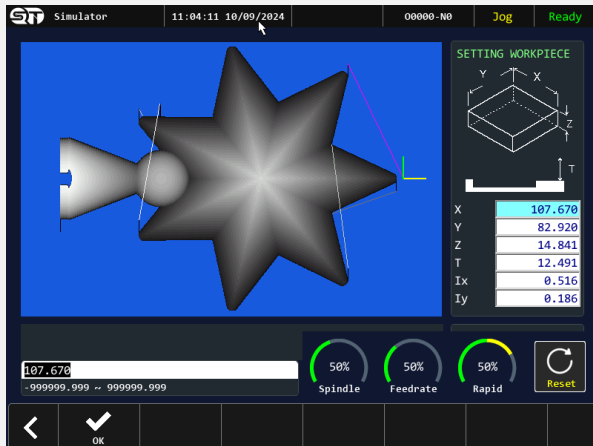

Memo

Model: ASTRO 6AH

Work set:

Allows the operators to refer or modify the working dimension of workpiece

Workpiece information

The operators can refer the minimum and maximum travel distance of workpiece

Toolpath view mode:

Allows the operators to simulate by multiple view models: Milling, Engraving 2D – Milling, Engraving 3D.

3.5.2 MDI MODE

Description Images

Model: ASTRO 6AH



Memo

Model: ASTRO 6AH

Step 1:

At first press the MDI button on control panel to switch to MDI mode. Then at monitor screen, press MDI button.

Step 2:

Enter a command for the controller. Press OK to confirm and CLEAR to start again.

3.5.3 AUTO OPTION MODE

This function assists the users when unexpected issues occur during to the machining process, leading to production interruptions.



Memo

Model: ASTRO 6AH

Step 1:

At monitor screen, press AUTO OPTION button.

Step 2:

Select working mode.

START FROM LINE: run from any command line in program.

CONTINUE: resume the working process that was stopped before.

SET NEW LINE: enter the line number then press this button before selecting START FROM LINE button.

NC CUT: automatically create secondary program to activate all necessary G-code before jumping to the last command feature

3.5.3.1 START PROGRAM FROM ANY COMMAND LINE

Description Images

Model: ASTRO 6AH

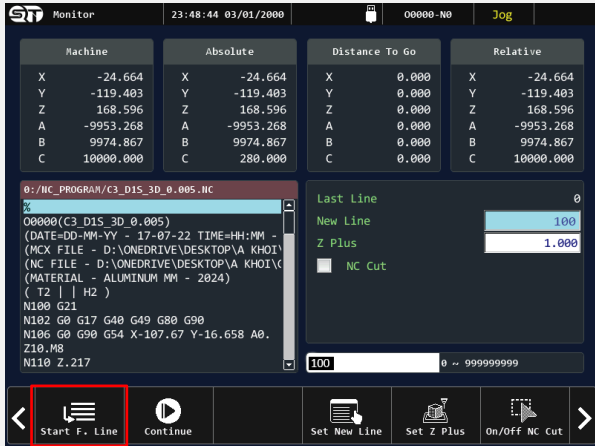
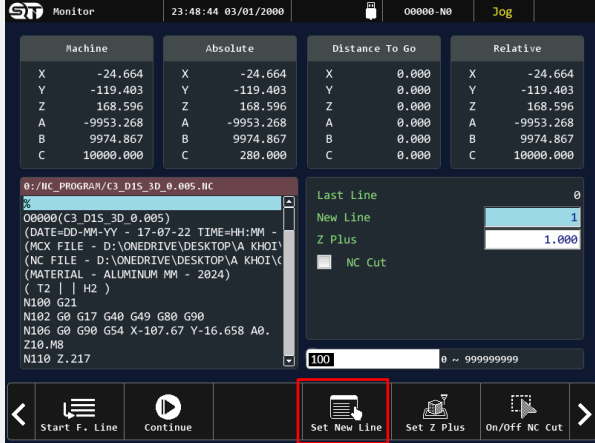

Memo

Model: ASTRO 6AH

Step 1:

Example, you want to go to command line 100. You will enter 100 and select SET NEW LINE button.

Step 2:

Press START FROM LINE button.

Description Images

Model: ASTRO 6AH

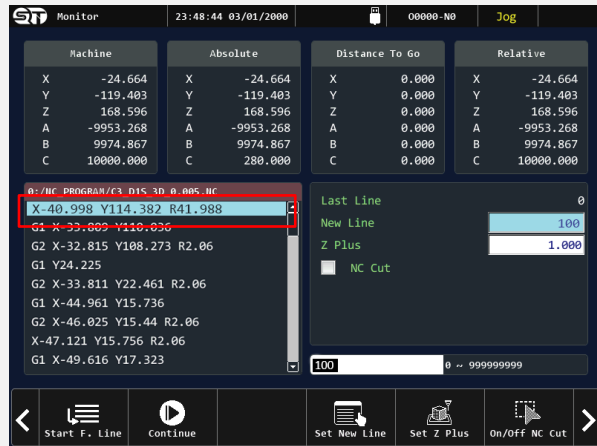

Memo

Model: ASTRO 6AH

Step 3:

Controller will go to command line 100.

3.5.3.2 CONTINUE THE WORKING PROCESS FROM THE LAST STOPPED COMMAND

Description Images

Model: ASTRO 6AH

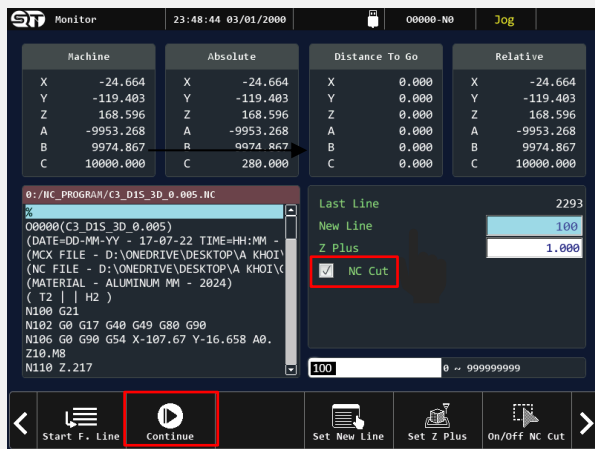
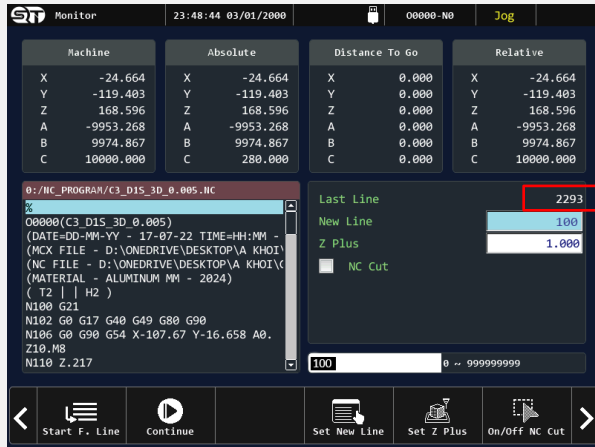

Memo

Model: ASTRO 6AH

Step 1:

Check the last command line on the right.

Step 2:

Press CONTINUE button. After that press switch to AUTO mode by pressing AUTO button on control panel. Final is pressing CYCLE START button.

Note:

NC CUT enable: When user continue the working process, controller will automatically create a secondary to activate all necessary G-Code before run to the last command line

NC CUT disable: When user continue the working process, controller will not create a secondary program to activate all necessary G-Code and jump to the last command directly

Description Images

Model: ASTRO 6AH

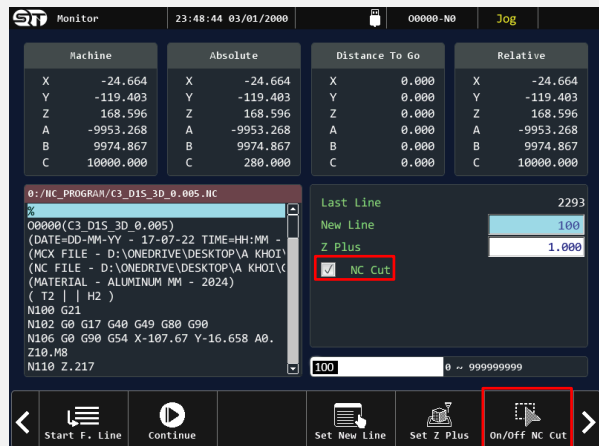

Memo

Model: ASTRO 6AH

Enable/Disable NC Cut feature

Press ON/OFF NC CUT button to enable or disable NC Cut feature.

3.5.4 WORKING HISTORY

Description Images

Model: ASTRO 6AH

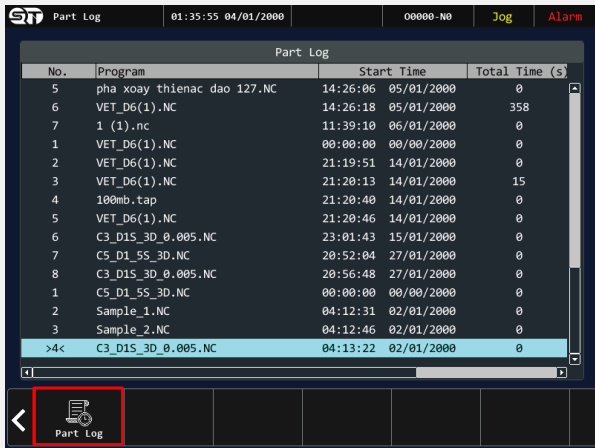
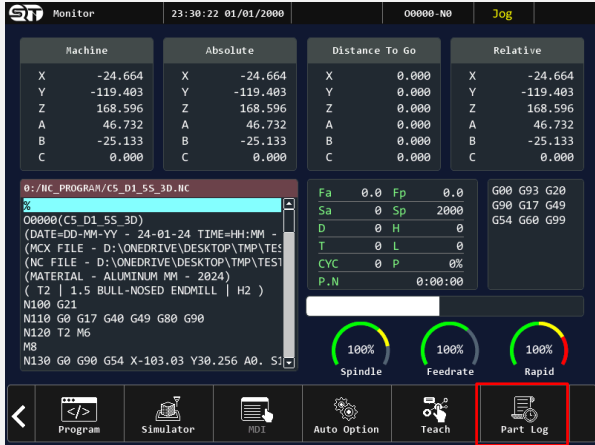

Memo

Model: ASTRO 6AH

Step 1:

Press PART LOG button to open the working history table.

Step 2:

Press PART LOG button to open the working history table. At this table you would be able to see the working history, name of program and the cycle time.

3.6 MAINTENANCE PAGE

Operators can monitor the error log, error notifications, and error alarms of the controller. To access the MESSAGE page, press the MESSAGE button from the main interface. Additionally, operators can save the error history for inspection when needed.

Maintenance features:

- **Alarm:** alarm history
- **Warning:** warning history
- **Operation:** operation history
- **Backup:** plug in the usb drive to controller and press this button to save all the error notifications to usb drive.

Model: ASTRO 6AH controller



Figure 3-6. Maintenance page

3.7 DIAGNOSTIC PAGE

QS Controllers support users with diagnostic tale. This table will allow users can monitor the system data bits, data registers and macro variables.

Diagnostic features:

- **NC bit:** open data bit page
- **NC register:** open register data page
- **Macro debug:** open macro variable page (local variables & global variables)

Model: ASTRO 6AH controller

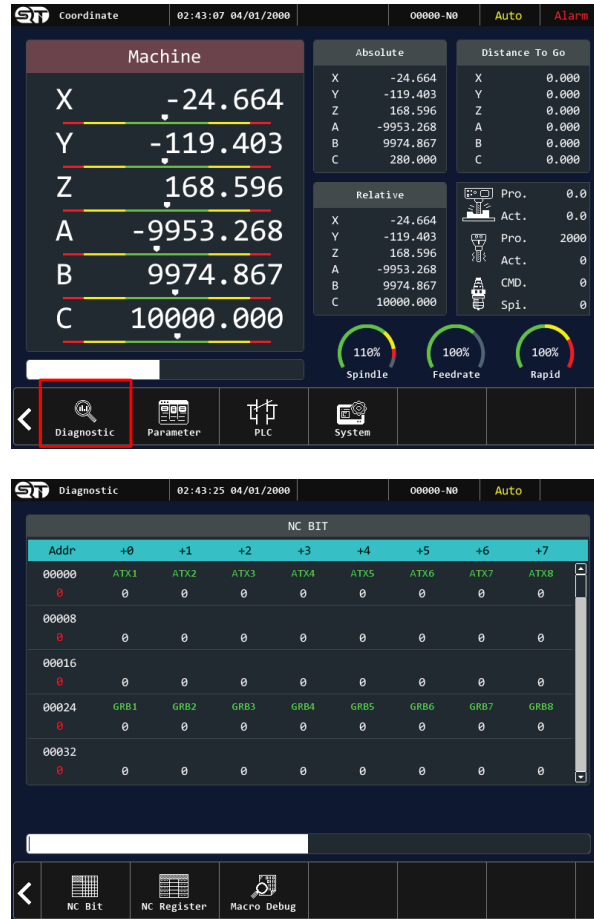

Figure 3-7. Diagnostic page

3.8 PARAMETER PAGE

The controller parameter page is a very important page. The operator needs to understand and know the parameters on the controller and absolutely not change them arbitrarily without fully understanding the function of that parameter. Because if the operator arbitrarily changes the parameters without understanding the function, it will lead to the machine malfunctioning, which can be dangerous, reduce the machine's productivity and affect the processing process.

Parameter feature:

- **General:** back to main page
- **Axis:** go to axis setting part
- **Spindle:** go to spindle setting part
- **Hardware:** go to hardware setting part

Model: ASTRO 6AH controller

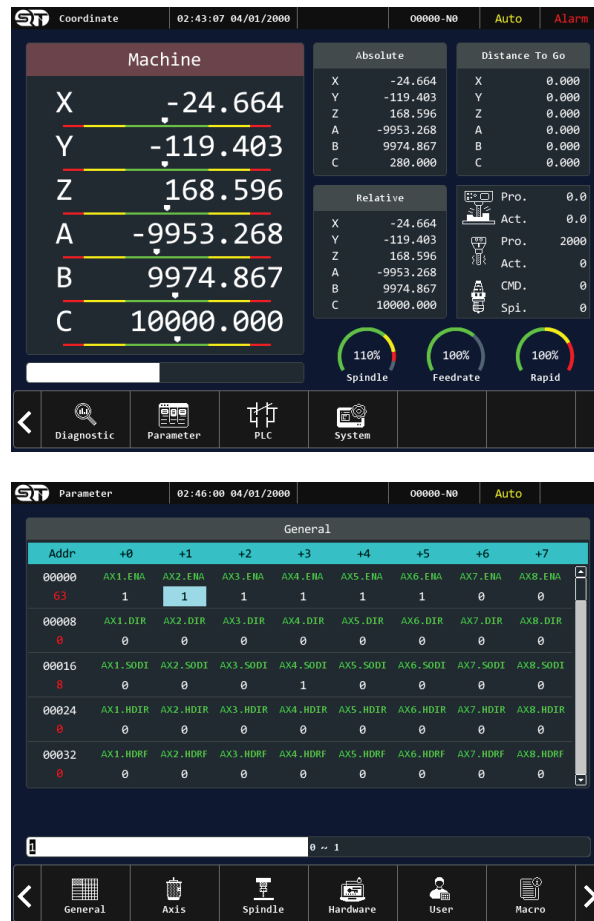

Figure 3-8. Parameter page

Parameter instruction parts:

- Parameter setting steps (3.8.1)

3.8.1 PARAMETER SETTING STEPS

Description Images

Model: ASTRO 6AH. ASTRO 6AH, Astro 6A, Astro 10i

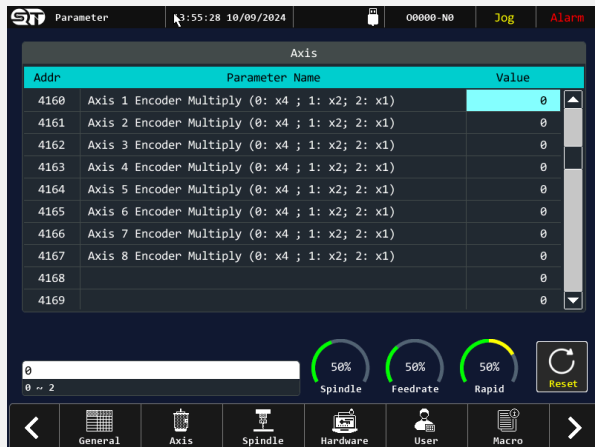
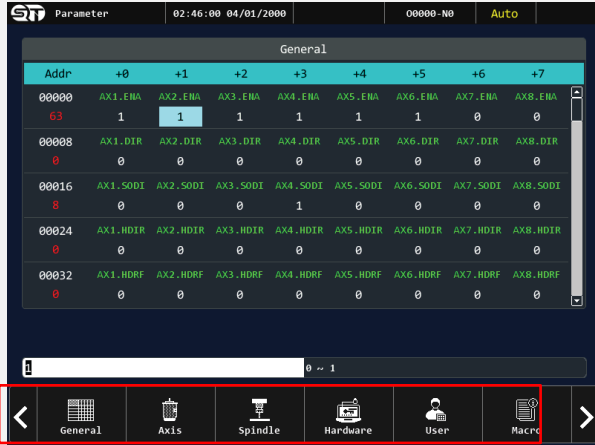

Page Down



Memo

Model: ASTRO 6AH, ASTRO 6AH, Astro 6A, Astro 10i

Step 1:

Select parameter type such as: Axis, Spindle, Hardware, Macro, ...

Step 2:

Press PAGE DOWN button to scroll the page down and find the parameter you are looking for.

Description Images

Model: ASTRO 6AH, ASTRO 6AH, Astro 6A, Astro 10i

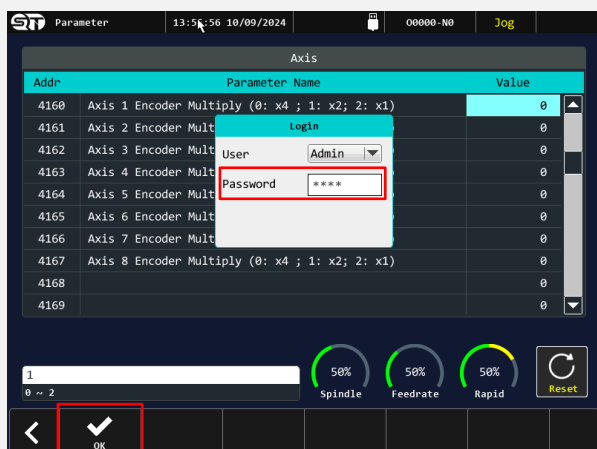
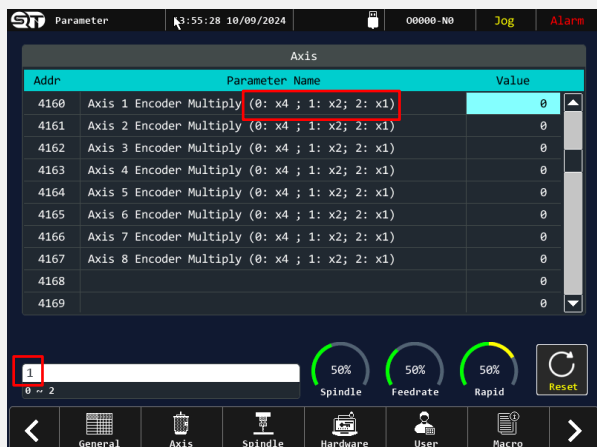

Memo

Model: ASTRO 6AH, ASTRO 6AH, Astro 6A, Astro 10i

Step 3:

Refer the information on the right of parameter. Then enter the suitable value.

Step 4:

At this time the system will request you to enter the user password. Enter "1415" and press OK button.

Description Images

Model: ASTRO 6AH, ASTRO 6AH, Astro 6A, Astro 10i

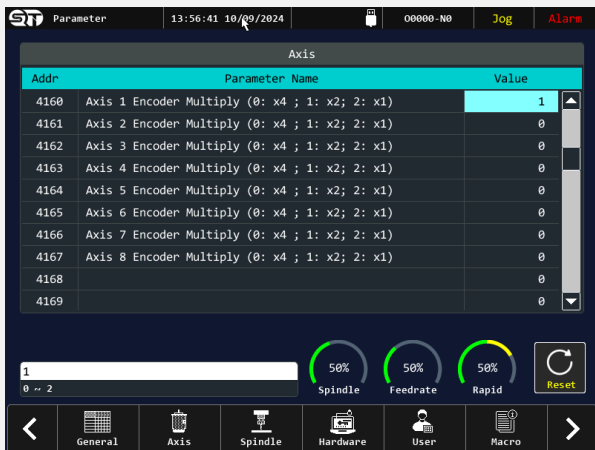
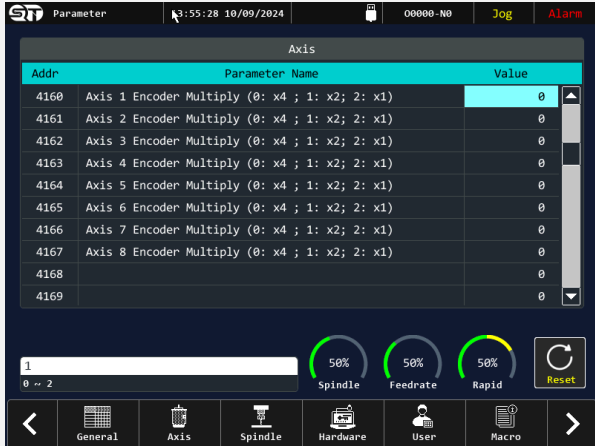

Memo

Model: ASTRO 6AH, ASTRO 6AH, Astro 6A, Astro 10i

Step 5:

Enter the value again. When you completed enter value, press RESET button on control panel to save data.

Step 6:

Reboot device to activate the new modified value.

3.9 PLC PAGE

QS controllers come with a PLC processor module, allows the users can monitor the operation status of machine. The user can prepare the PLC ladder program then import it to controller to suitable with your applications.

PLC features:

- **SYS BIT:** open system bit page
- **SYS REG:** open system registers data page
- **FIND REV:** find previous object in ladder program
- **FIND NEXT:** find next object in ladder program

Model: ASTRO 6AH controller

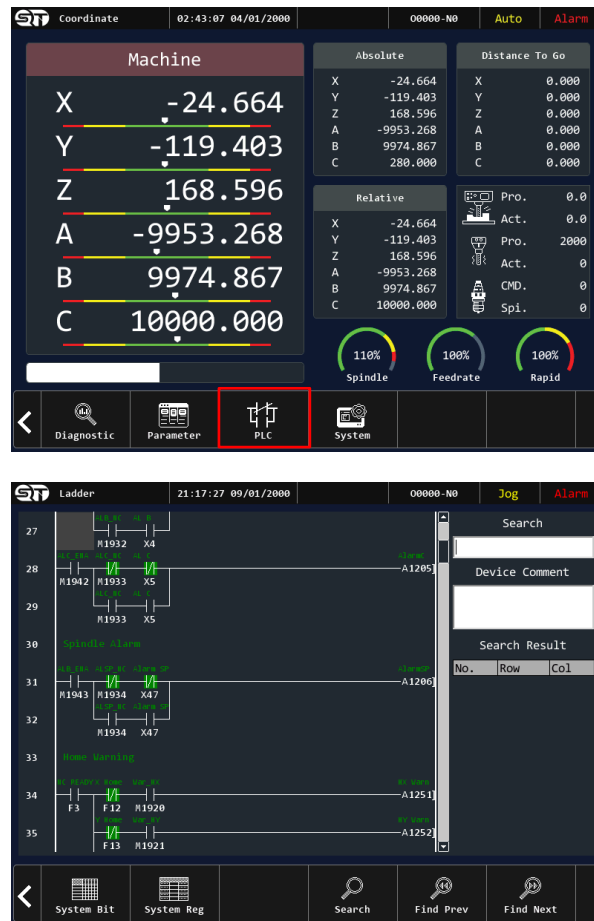

Figure 3-9 PLC page

PLC instruction parts:

- Find an object in ladder program **(3.9.1)**
- Import PLC data **(3.9.2)**

3.9.1 FIND AN OBJECT IN LADDER PROGRAM

Description Images

Model: ASTRO 6AH, ASTRO 6AH, Astro 6A, Astro 10i

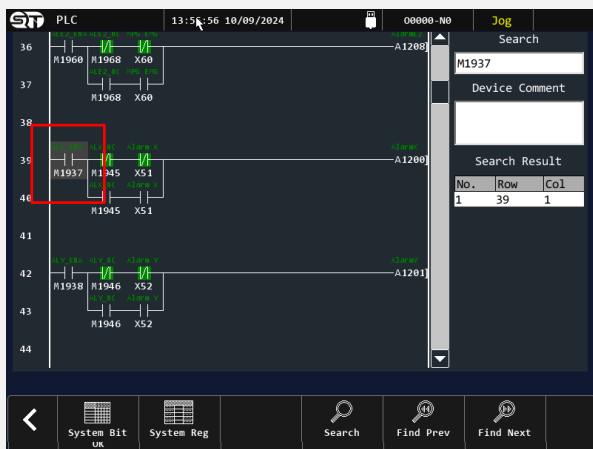
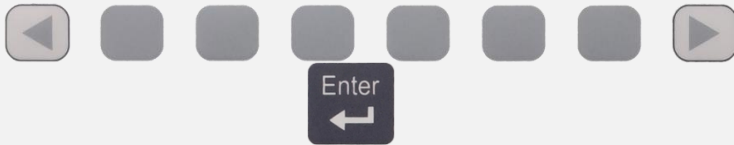
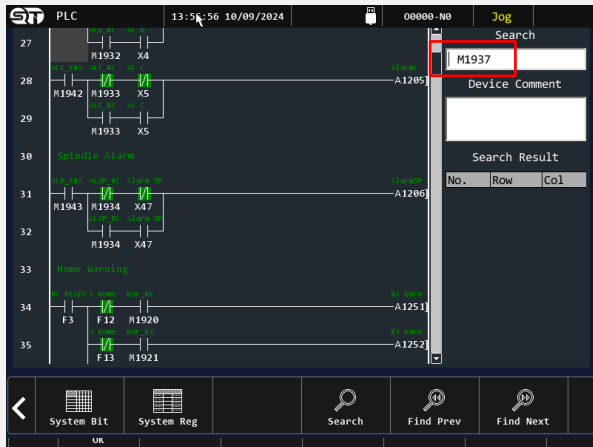

Memo

Model: ASTRO 6AH, ASTRO 6AH, Astro 6A, Astro 10i

Step 1:

Fill the object name and press ENTER button on control panel.

Step 2:

Controller will find the object if it is existing in program. If you want to check is there any object have the same name, press FIND NEXT and FIND REV button.

3.9.2 IMPORT PLC DATA

To successfully load data into the controller, operators must understand the directory formats. If the directory names or formats are incorrect, the data will not be loaded.

- Directory Formats on the ASTRO 6AH Controller

Number	Data Type	Standard Name	Standard Format	Final Format
1	PLC	ALM_PLC_USER PLC	.HPL	ALM_PLC_USER.HPL PLC.HPL



Memo
Model: ASTRO 6AH, ASTRO 6AH, Astro 6A, Astro 10i

Step 1:
Press SYSTEM button.

Step 2:
Login and enter user password "1415".

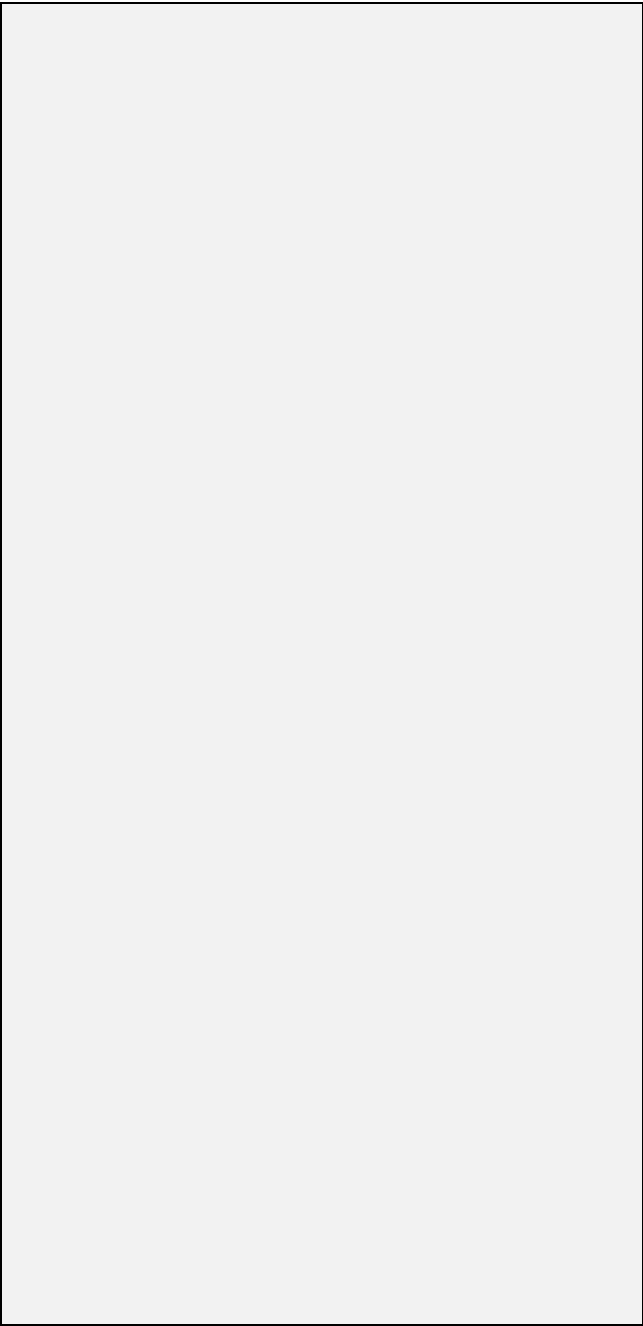
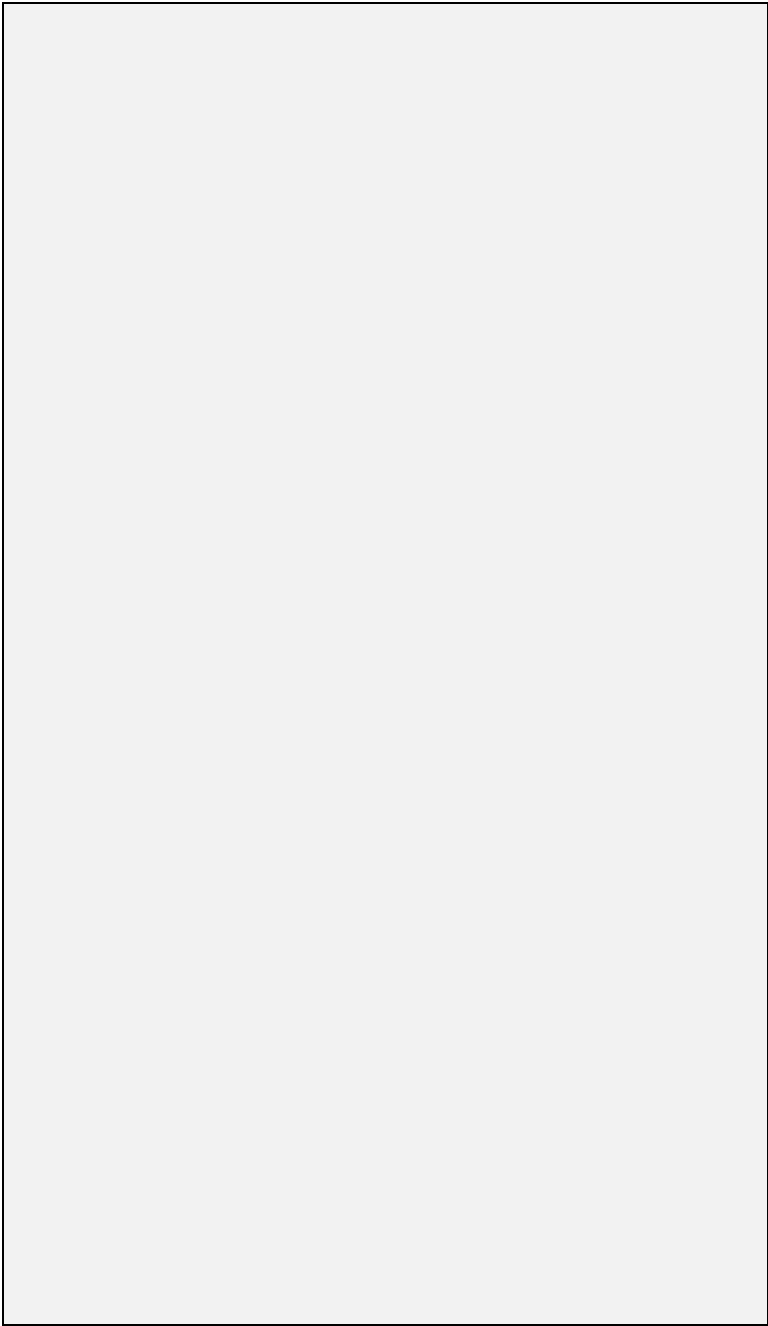

Description Images

Model: ASTRO 6AH

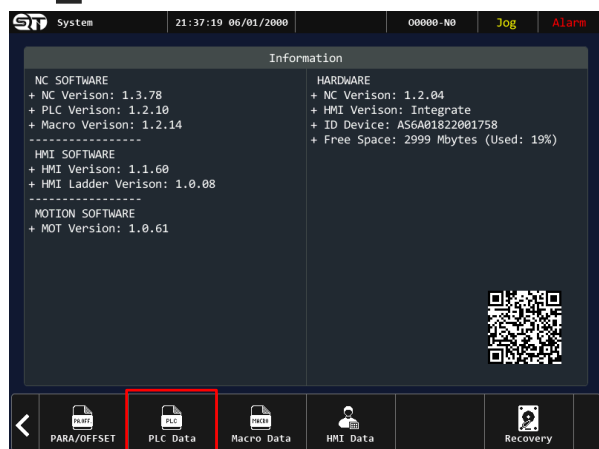

Memo

Model: ASTRO 6AH

Step 3:

Press DATA I/O button. You can select to load (Macro/PLC/Parameter/Offset, HMI)

Step 4:

Press PLC DATA button.

Description Images

Model: ASTRO 6AH

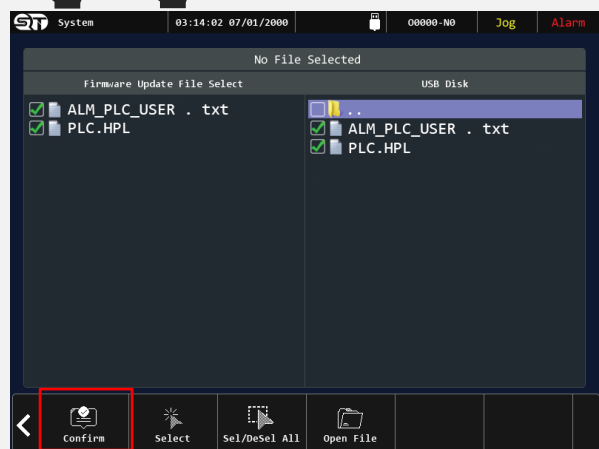

Memo

Model: ASTRO 6AH

Step 5:

Select UPDATE or BACKUP

Step 6:

Plug in the USB drive with the PLC data to the controller. At this point, the controller will automatically detect the PLC file. You only need to check it and press the CONFIRM button.

3.10 SYSTEM SETTING

Operators access the SYSTEM page to configure system changes, load, and export controller data.

To successfully load data into the controller, operators must understand the directory formats. If the directory names or formats are incorrect, the data will not be loaded.

- Directory Formats on the ASTRO 6AH Controller

Number	Data Type	Standard Name	Standard Format	Final Format
1	Macro alarm	ALM_MACRO_USER	.txt	ALM_MACRO_USER.txt
2	Parameter	PARAM_NC PARAM_USER	.txt	PARAM_NC.txt PARAM_USER.txt
3	Offset	OFFSET	.txt	OFFSET.txt
4	PLC	ALM_PLC_USER PLC	.HPL	ALM_PLC_USER.HPL PLC.HPL

Notes:

Macro programs are typically created using a text editor such as Notepad and saved with a .txt file extension. Before loading the macro program into the controller, the programmer must remove the .txt file extension.

Example:

A macro program created using Notepad is named "M0100.txt". The operator must remove the .txt file extension before loading the file into the controller.

M0100.txt → M0100

To load data into the controller, the operator must follow these steps:

SYSTEM Page Features:

- **DATA I/O:** Import and export data such as parameters, offsets, PLC, and HMI.
- **FIRMWARE:** Update and save device firmware versions.
- **SYS.INIT:** Configure other features such as time settings.

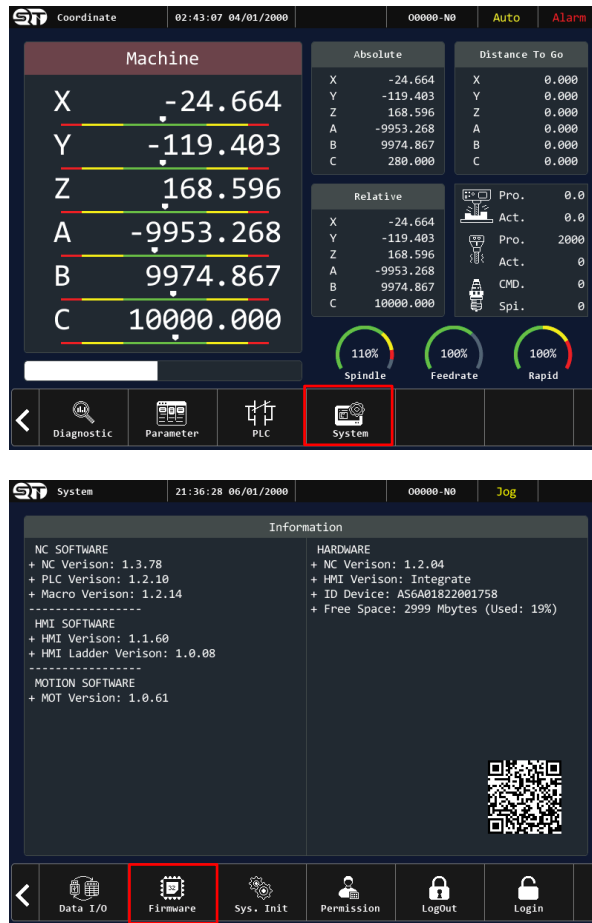

Figure 3-10. System page

System instruction parts:

- Firmware update **(3.10.1)**
- Date & Time setting **(3.10.2)**

3.10.1 FIRMWARE UPDATE

Description Images

Model: ASTRO 6AH

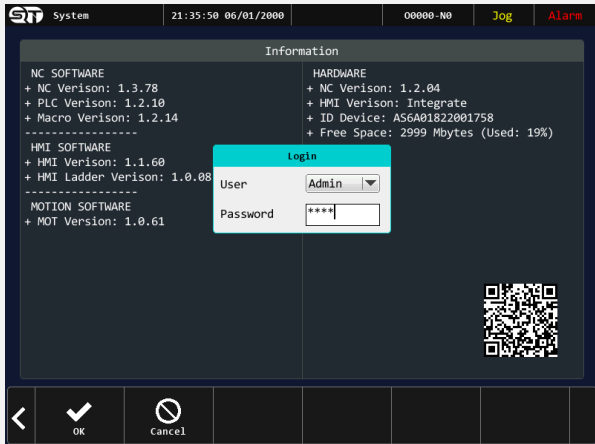
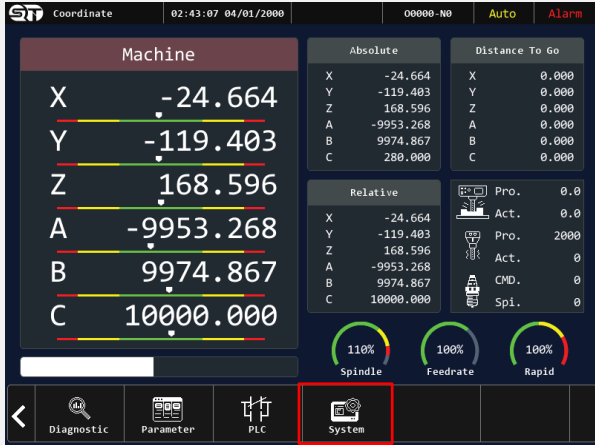

Memo

Model: ASTRO 6AH

Step 1:

Press SYSTEM button.

Step 2:

Enter user password "1415".

Description Images

Model: ASTRO 6AH



Memo

Model: ASTRO 6AH

Step 1:

Login to system and select FIRMWARE button.

Step 2:

Press UPDATE button.

Description Images

Model: ASTRO 6AH

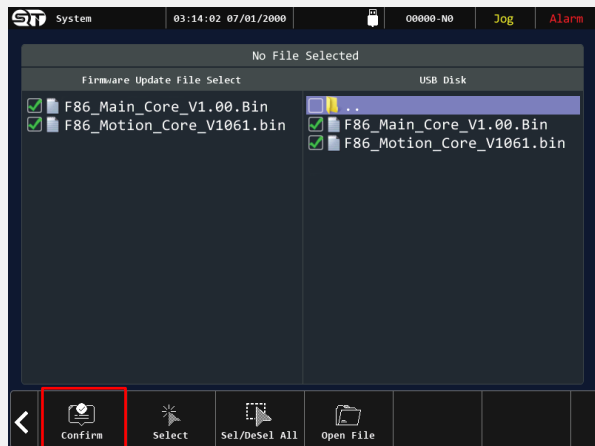

Memo

Model: ASTRO 6AH

Step 3:

Plug in the USB drive with the firmware data to the controller. At this point, the controller will automatically detect the firmware file. You only need to check it and press the CONFIRM button.

Note:

The firmware for the controller is named as follows:

- ASTRO 6AH_Main_Core_V1.00.Bin
- ASTRO
6AH_Motion_Core_V1061.Bin

3.10.2 DATE & TIME SETTING

Description Images

Model: ASTRO 6AH

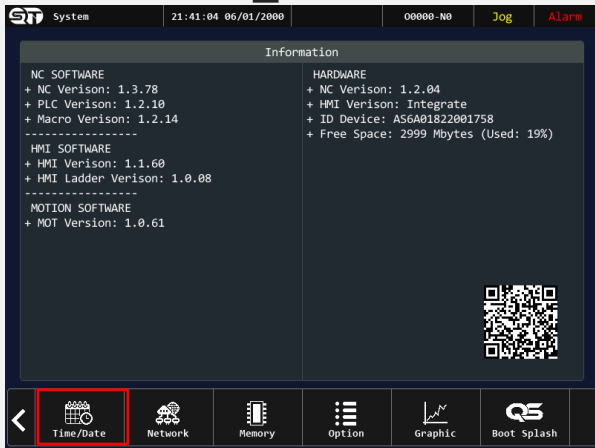

Memo

Model: ASTRO 6AH

Step 1:

Login to system and select SYS.INT button.

Step 2:

Press TIME/DATE button.

Description Images

Model: ASTRO 6AH, ASTRO 6AH, Astro 6A, Astro 10i

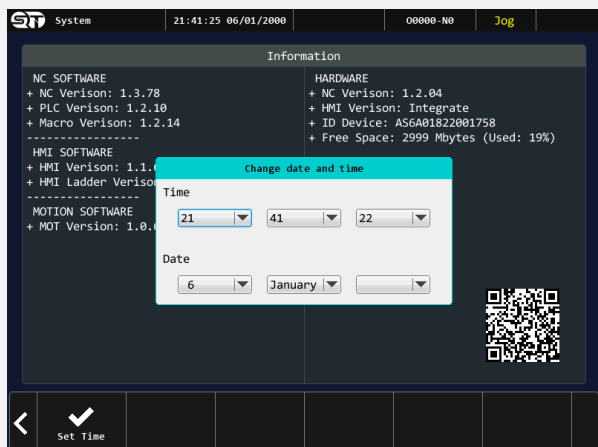

Memo

Model: ASTRO 6AH, ASTRO 6AH, Astro 6A, Astro 10i

Step 3:

Establish date, time value. And press SET TIME button.

3.11 TOOL LENGTH MEASUREMENT SENSOR

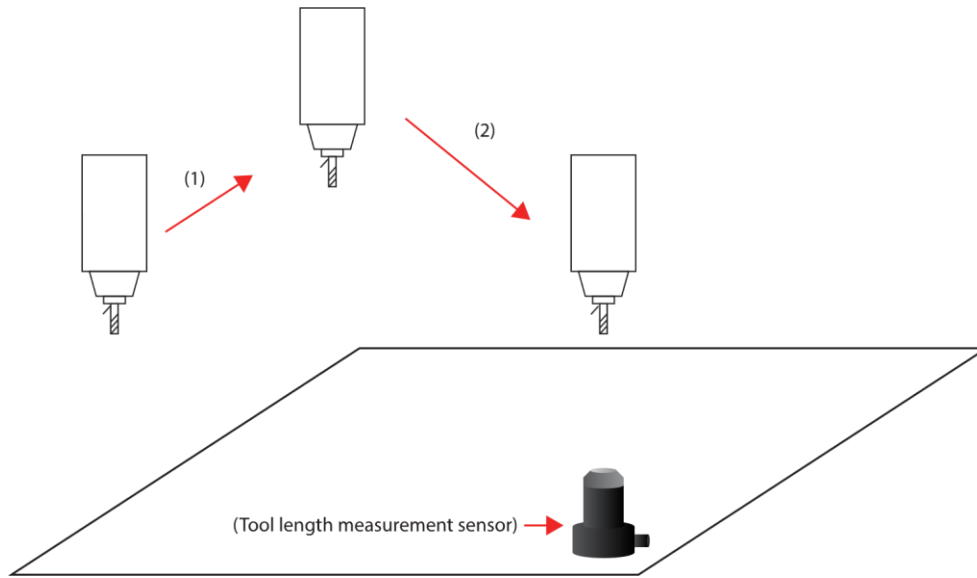

Stage 1:

When M100 is called the coolant system will be turned off, at this time, the Z axis, which is at a random position, will start to return to home position.

Stage 2:

The controller will move X,Y axis and tool head to the measurement point were established in parameter (#14003 & #14004)

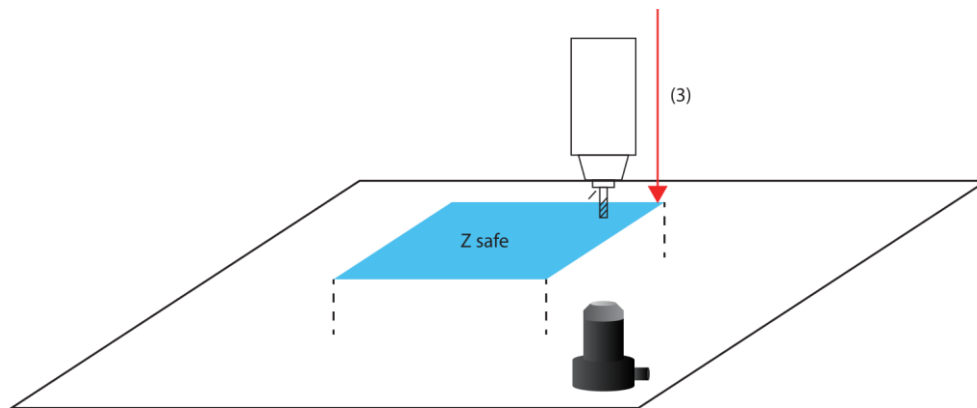

Stage 3:

At this time Z axis will quickly move to the safety position (Z safe) established in (#14005)

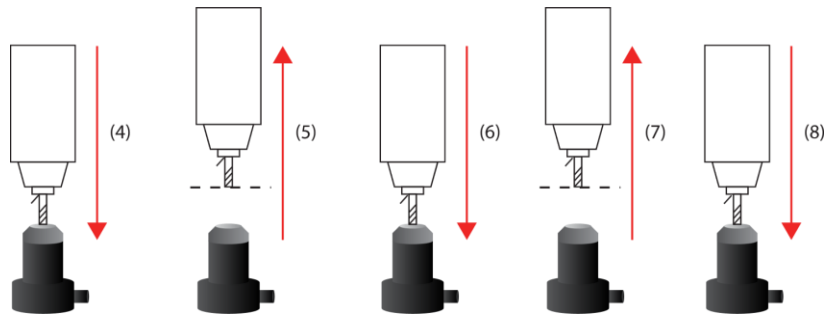

Stage 4, 5:

Z axis will move and touch to the sensor for the first time by the speed established in **#14007**.

After touch the sensor, Z axis will move up a distance established in **#14008**.

Stage 6, 7:

Z axis will move and touch to the sensor for the second time by the speed established in **#14009**.

After touch the sensor, Z axis will move up a distance established in **#14010**.

Stage 8:

Z axis will move and touch to the sensor for the third time by the speed established in **#14011**.

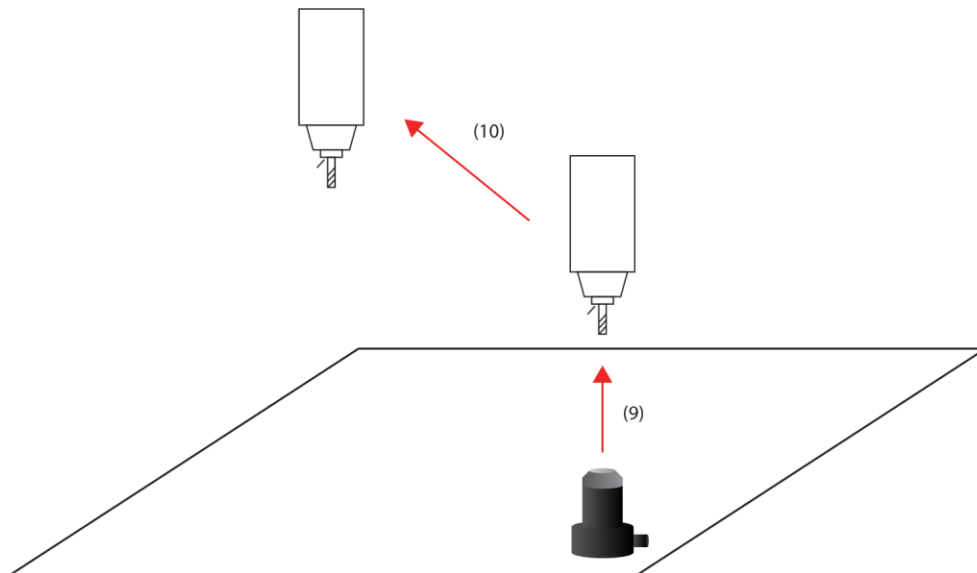

Stage 9:

After touch the sensor, Z axis will start to return to home position.

Stage 10:

At this time the Macro will use the measurement values of the second and the third time to compare. If the both touch time have the deviation is higher than established value in **#14012**. The controller will announce an error and the value will not be set to the H Offset.

Note:

At stage **(4, 5)**. In case Z axis moved the tool head to sensor touch position established in **#14006** but still not touch the sensor. Then the controller will announce an error.

- The issue is the travel limit of #14006 is not correct. The operators need to refer the value established in **#14006**

In case Z axis has raised the tool head by the value established in **#14008** but the probe signal still not disappear. Then the controller will announce an error.

- The issue is the distance to raise the tool head of Z axis is too small or the sensor is having the problem. The operators need to refer the value in **#14008** and the sensor.

At stage **(5, 6)**. In case Z axis moved the tool head to sensor touch position established in **#14006** but still not touch the sensor. Then the controller will announce an error.

- The issue is the travel limit of #14006 is not correct. The operators need to refer the value established in **#14010**

In case Z axis has raised the tool head by the value established in **#14010** but the probe signal still not disappear. Then the controller will announce an error.

- The issue is the distance to raise the tool head of Z axis is too small or the sensor is having the problem. The operators need to refer the value in **#14010** and the sensor.

At stage **(7)**. In case Z axis moved the tool head to sensor touch position established in **#14006** but still not touch the sensor. Then the controller will announce an error.

- The issue is the travel limit of #14006 is not correct. The operators need to refer the value established in **#14006**

At stage **(10)**

- **Case 1:** Call M100 command
 - o The average value will be set to Offset H correspond to the current tool in the spindle
 - o Ex: the current tool in the spindle is T5 then the average value will be set to Offset H5
- **Case 2:** Call M100Hxxx command
 - o The average value will be set to Offset H correspond to H called before
 - o Ex: Call M100H3 then the average value will be set to Offset H3

CHAPTER 4.

PARAMETER INSTRUCTIONS



4.1 AXIS PARAMETER

Parameter	Description	Work range	Default
#0000 - #0007	Axis enable(AX.ENA)	0:Disable – 1:Enable	0
#0008 - #0015	Axis direction(AX.DIR)	0:Disable – 1:Enable	0
#0016 - #0023	Axis soft limit disable feature(AX.SODI)	0:Disable – 1:Enable	0
#0024 - #0031	Axis home direction(AX.HDR)	0: Forward – 1: Reverse	0
#0032 - #0039	Axis home offset(AX.HDRF)	0:Disable – 1:Enable	0
#0040 - #0047	Axis home fast(AX.HFAS)	0:Disable – 1:Enable	1
#0056 - #0063	MPG direction(MPG.DIR)	0: Forward – 1: Reverse	0
#0088 - #0095	Axis pulse logic(AX.PLG)	0: Low level – 1: High level	0
#0128 - #0135	Encoder direction(ENC.DIR)	0:Disable – 1:Enable	0
#4000	Motion corner velocity control model	0 – 5	0
#4001	Motion corner smooth max level	1 - 100	1
#4002	Motion corner smooth min level	1 - 100	1
#4003	Motion ARC refill buffer percent(%)	0 - 50	0
#4010 - #4017	Axis zero digit visible	0 - 99999	0
#4020 - #4027	Axis homing type	0: DOG on 1: DOG off 2: INDEX	0
#4030	Axis home search dog times	0 – 5	0
#4040 - #4047	Axis name	65 – 90	0
#4050 - #4057	Axis sensor type	0: NU type 1: ENC type 2: RULE type 3: ABS type	0
#4060 - #4067	Axis pulse out	0: Pul/Dir type 1: CW/CCW type 2: A/B type	0
#4070 - #4077	Axis backlash	0: Disable 1: Lin GW type 2: Box GW type	0
#4080 - #4087	Axis alarm sensor	0: Disable 1: NC type 2: NO type	0
#4140 - #4147	Axis type	0: Linear 1: Rotary 1 2: Rotary 2	0
#4150 - #4157	Axis encoder port	0: Disable 1: port 1 2: port 2 3: port 3 4: port 4 5: port 5 6: port 6	0
#4160 - #4167	Axis encoder multiply	0: X1 1: X2 2: X4	0
#8010	Init rapid override (%)		3
#8011	Init federate override (%)		5
#8013	Feedrate default (mm/min)		3000
#8080 - #8087	Axis position loop gain (1/sec)		0

#8090 - #8097	Axis dir signal delay (0.1us)	200
#8150, #8152 #8154	Radius minimum limit federate (um) (1 st , 2 nd , 3 rd)	1000/5000/10000
#8151, #8153 #8155	Radius maximum limit federate (um) (1 st , 2 nd , 3 rd)	1000/3000/6000
#8170, #8172 #8174	Segment length limit federate (um) (1 st , 2 nd , 3 rd)	500/2000/6000
#8171, #8173 #8175	Auto interpolation limit rate (mm/min)	2000/4000/6000
#8180 - #8187	Axis short segment acceleration (mm/s/s)	1000
#8190 - #8197	Axis G00 backlash time (ms)	50
#8200 - #8207	Axis G01 backlash time (ms)	50
#12000 - #12007	Axis pitch mount (BLU)	10000
#12010 - #12017	Axis pulse/mm (BLU)	1000
#12020 - #12027	Axis rapid travel acceleration (m/s/s) G00	1000
#12030 - #12037	Axis cutting acceleration (m/s/s) G01	500
#12040 - #12047	Axis max jog rapid (mm/min)	12000
#12050 - #12057	Max jog federate (mm/min)	6000
#12060 - #12067	Axis max auto rapid (mm/min)	12000
#12070 - #12077	Axis max auto federate (mm/min)	12000
#12080 - #12087	Axis loss pulse check window (BLU)	0
#12090 - #12097	Axis homing federate 1 st (mm/min)	2000
#12100 - #12107	Axis homing federate 2 nd (mm/min)	200
#12110 - #12117	Axis homing federate 3 rd (mm/min)	100
#12120 - #12127	Axis home offset (BLU)	0
#12130 - #12137	Axis MPG acceleration (mm/s/s)	1000
#12140 - #12147	Axis MPG max speed (mm/min)	8000
#12150 - #12157	Axis backlash G00 (BLU)	0
#12160 - #12167	Axis backlash G01 (BLU)	0
#12200 - #12207	Axis negative coordinate of stroke limit 1 st (BLU)	0
#12210 - #12217	Axis positive coordinate of stroke limit 1 st (BLU)	0
#12220 - #12227	Axis negative coordinate of stroke limit 2 nd (BLU)	0
#12230 - #12237	Axis positive coordinate of stroke 2 nd (BLU)	0
#12240 - #12247	Axis negative coordinate of stroke limit 3 rd (BLU)	0
#12250 - #12257	Axis positive coordinate of stroke 3 rd (BLU)	0
#12260 - #12267	Axis negative coordinate of stroke 4 th (BLU)	0
#12270 - #12277	Axis positive coordinate of stroke 4 th (BLU)	0
#12280 - #12287	Axis reference point 2 nd (BLU)	0
#12290 - #12297	Axis reference point 3 rd (BLU)	0
#12300 - #12307	Axis reference point 4 th (BLU)	0
#12310 - #12317	Axis reference point 5 th (BLU)	0
#12320 - #12327	Axis reference point 6 th (BLU)	0
#12330 - #12337	Axis jogging acceleration (mm/s/s)	1000
#12340 - #12347	Axis gear (Motor side)	1
#12350 - #12357	Axis gear (Screw side)	1
#12360 - #12367	Axis encoder pulse/round	0

4.2 SPINDLE PARAMETER

Parameter	Description	Work range	Default
#0104	RES.CODE	0: Default S.code 1: Last S.code	0
#0120 - #0123	Spindle direction (SPI.DIR)	0: Forward – 1: Reverse	0
#4090 - #4093	Spindle mode	0: Disable 1: 0→10V 2: 0→±10V	0
#8020	Init spindle override (%)	0 → 10	5 (= 50%)
#8030, #8032 #8034, #8036	Spindle(1) – Gear (1,2,3,4) (Motor side)	0 – 999999	1
#8031, #8033 #8035, #8037	Spindle(1) – Gear (1,2,3,4) (Screw side)	0 – 999999	1
#8040, #8042 #8044, #8046	Spindle(2) – Gear (1,2,3,4) (Motor side)	0 – 999999	1
#8041, #8043 #8045, #8047	Spindle(2) – Gear (1,2,3,4) (Screw side)	0 – 999999	1
#8050, #8052 #8054, #8056	Spindle(3) – Gear (1,2,3,4) (Motor side)	0 – 999999	1
#8051, #8053 #8055, #8057	Spindle(3) – Gear (1,2,3,4) (Screw side)	0 – 999999	1
#8060, #8062 #8064, #8066	Spindle(4) – Gear (1,2,3,4) (Motor side)	0 – 999999	1
#8061, #8063 #8065, #8067	Spindle(4) – Gear (1,2,3,4) (Screw side)	0 – 999999	1
#8070 - #8073	Spindle (1,2,3,4) float gear motor speed (rpm)	0 – 999999	1
#12170 - #12173	Spindle (1,2,3,4) min speed (rpm)	0 – 999999	10
#12175 - #12178	Spindle (1,2,3,4) max speed (rpm)	0 – 999999	24000
#12180 - #12183	Spindle (1,2,3,4) motor gain analog mode (rpm/volt)	0 – 999999	1
#12185 - #12188	Spindle (1,2,3,4) init speed (rpm)	0 – 999999	1
#12190 - #12193	Spindle (1,2,3,4) acceleration (ms)	0 – 999999	5000
#12195 - #12198	Spindle (1,2,3,4) deceleration (ms)	0 – 999999	5000
#12370 - #12373	Spindle (1,2,3,4) max frequency pulse mode	0 – 999999	200

4.3 GENERAL PARAMETER

Parameter	Description	Work range	Default
#0064	G54 default (G54.DEF)	0: Disable – 1: Enable	0
#0065	All position clear (POS.CLR)	0: Forward – 1: Reverse	0
#0066	G04 assignment: X(s) – P(ms). (G04.X/P)	0: G04 X 1: G04 P	0
#0072	MTAD.PRO (Available on touch controller)	0: Disable – 1: Enable	0
#0073	MTAD.CRE (Available on touch controller)	0: Disable – 1: Enable	0
#0074	MTAD.MDI (Available on touch controller)	0: Disable – 1: Enable	0
#0080	JOG.ACC	0: Run by cutting speed 1: Run by jog acceleration	1
#0081	CON.FEED		0
#0096	3DP.EAX		0
#0097	NC.CUT	0: Disable – 1: Enable	0
#0098	3DL.FEED		0
#0112	G99/G98	0: Enable G99 & Disable G98 1: Enable G98 & Disable G99	0
#0136	OPK.DISA (Not available on ASTRO 6AH controller)	0: Disable – 1: Enable	0
#4130	Backup battery	0: Disable – 1: Enable	1
#4131	Reset battery alarm	0: Disable – 1: Enable	0
#4132	Touch panel type (Available on touch controller)		
#4133	LCD panel type (Available on touch controller)		
#4134	Touch panel (Available on touch controller)		
#4135	Speaker	0: Disable – 1: Enable	1
#4136	LCD sleep (min)		15
#4137	Wi-Fi function	0: Disable – 1: Enable	0

4.4 USER PARAMETER

Parameter	Description	Work range	Default
#2000 - #2079	User defined 16 bit register		0
#10000 - #10049	User defined 16 bit register		0
#14000 - #14049	User defined 32 bit register		0

4.5 MACRO PARAMETER

Parameter	Description	Work range	Default
#0048	T.Macro	0: Disable – 1: Enable	0
#0049	Macro.M98	0: Disable – 1: Enable	0
#8110 - #8129	M Macro ID	0 – 999 (0: Disable)	0
#8130 - #8149	G Macro ID	0 – 999 (0: Disable)	0